

## Installation, Operation Maintenance Instructions for 1600 Series Globe Control Valve

### TYPICAL UN-BALANCED VALVE – PARTS

**Figure 1: Severn 1600 Series Control Valve – Cut section view.**

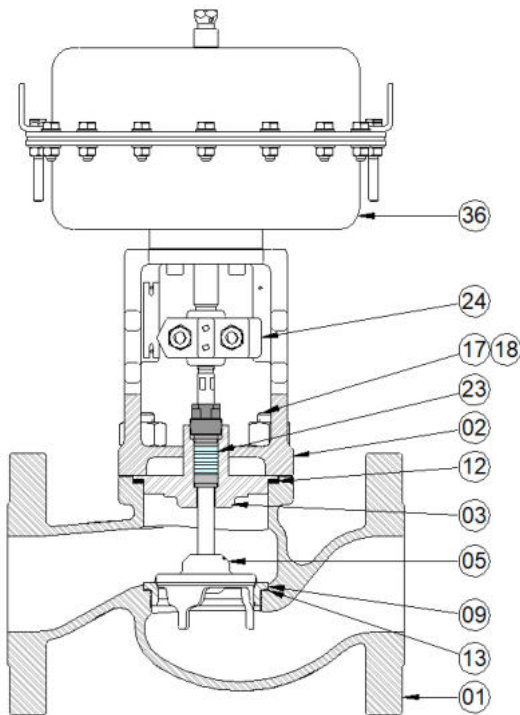

**Table 1:**

Item No	Description
01	Body
02	Integral Yoke + Bonnet
03	Bonnet Spacer
05	Plug + Stem
09	Screwed Seat
12	Body Gasket
13	Seat Gasket
17	Stud
18	Nut
23	Stuffing Box Components*
24	Split Clamp
36	Multi Spring Actuator

**Note:** \* Refer Figure 4

### INFORMATION

The purpose of this manual is to guide the process of unpacking, installation and maintenance of 1600 series Severn control valves. It is highly recommended that the users and personnel responsible for maintenance. Read the manual before proceeding to install, operate, or perform any procedures on the valve. Ensure instructions as per the manual are followed to avoid mishaps and injuries. For further information, the User shall refer to 'BS6683' – Guide to installation and use of valves.

### GENERAL INSPECTION OF PARTS

#### MAINTENANCE ITEMS ARE:

**Advanced Inspection** – (to be carried out by trained personnel only)

Stuffing Box Components (Packing Rings / Packing washer) – Not re-useable

SOFT SEATS - Not re-useable

GASKETS (Body & Seat Gasket, Body & Bonnet Gasket) - Not re-useable.

PLUG / SEAT – If damaged contact Severn for advice on repair or whether replacement is needed.

### INTENDED USE

Reference is to be made to the Valve Specification / Data Sheet, Installation and Operation Instructions, and nameplate to check the product is suitable for the intended use/application.

SEVERN		SEVERN GLOBE VALVES PRIVATE LIMITED.	
P-96697, SPCOT IND. PARK, CHENNAI 602 117, INDIA			
SERIAL No.		TAG No.	
ORDER No.		BODY MATL.	
SERIES	YEAR MFG.	TRIM MATL.	
SIZE	RATING	LEAKAGE CLASS	TRAVEL
PORT SIZE	ACT MODEL	SUPPLY PRESS	SIGNAL
CV/CHAR		SPRING RANGE	AIR FAIL
MAX. ALLOW. PRESS. & TEMP.		M.N. ALLOW. PRESS. & TEMP.	
Read manufacturer's instructions prior to installation and use.			

A sample nameplate is shown above, showing maximum and minimum pressure/temperature.

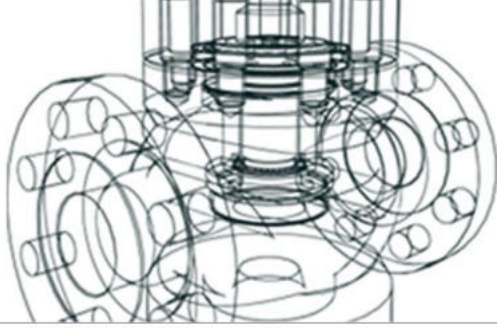

### Installation, Operation Maintenance Instructions for 1600 Series Globe Control Valve

**Warning: Standard industry safety practices are to be strictly followed.**



Always wear appropriate PPE and ensure that the local lifting plan is followed



Always ensure a safe working environment when lifting



**Always isolate the valve before maintenance. Always use lockout methods to ensure safety.**



**Caution: The valve may be extremely hot or cold. Caution: Do not put your hands inside the valve**



**Always use the correct tools. Do not over-tighten. Do not use extension bars to force movement.**



**Poison risk: Do not incinerate PTFE. Do not smoke whilst handling PTFE.**



**Always read the manual. If any doubts exist, contact Severn quoting the valve serial number.**

**WARNING:** When ordered, the control valve configuration and materials of construction are selected to meet particular pressure, temperature, pressure drop, and controlled fluid conditions. Personal injury, property damage, equipment damage, or leakage due to escaping gas or bursting of pressure-containing parts may result if the control valve or its ancillaries are over-pressured or installed where service conditions exceed the valve design limits. To avoid such injury or damage, provide a relief valve for overpressure protection as required by accepted industry or local codes and good engineering practice. Do not apply other conditions to the valve without written approval from Severn.

**WARNING:** Before performing any maintenance operation: Isolate the control valve from process pressure. Relieve process pressure from both sides of the control

valve. Drain the process media from both sides of the valve. If the control valve is to be removed from the line decontaminate any process fluid remaining in the valve to make it safe.

Disconnect and isolate any operating lines providing air pressure, electric power, or a control signal to the actuator. Vent the air pressure from the actuator. Be sure that the actuator cannot suddenly open or close the valve (Note by disconnecting the air and or power lines the actuator will move the valve to its power failure position). Ensure persons are at a suitable distance from moving parts.

Use lock-out procedures to be certain that the above measures stay in effect whilst work is carried out on the control valve.

#### **MACHINERY DIRECTIVE 2006/42/EC INCORPORATED INTO A MACHINE**

**Note:** This product certificate is not in scope of this product.

Severn valves must not be put into service until the machinery into which they are to be incorporated has been declared in conformity with the provisions of the Machinery Directive. Severn valves must not be used as Safety Components (Emergency Shutdown Valves) within the meaning of the Machinery Directive without prior notification to Severn.

#### **ATEX DIRECTIVE 2014/34/EU**

**Note:** This product certificate is not in scope of this product.

Under the ATEX Directive, a risk assessment is necessary by the end user to justify the basis of safety.

#### **PRESSURE EQUIPMENT DIRECTIVE PED 2014/68/EU**

**Note:** This product certificate is not in scope of this product.

It is a requirement of the PED that both the maximum and minimum working pressures and temperatures of the valve are recorded on the nameplate. Refer to the actual nameplate attached to the valve and the Control Valve Specification Sheet (CVSS) was issued with the valve to check the valve is suitable for its intended use.

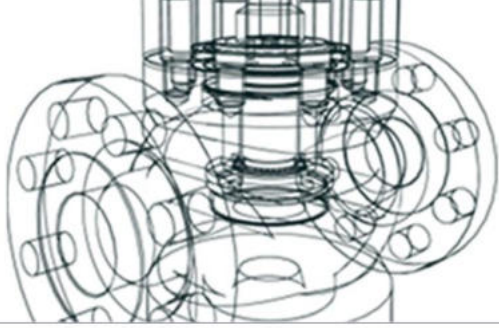

## Installation, Operation Maintenance Instructions for 1600 Series Globe Control Valve

Attention must be paid to the combined pressure and temperature characteristics of the appropriate valve material group as stated in ASME B16.34, API 6A or relevant international standards.

Reference is to be made to the Control Valve Specification Sheet, Installation and Operation Instructions and nameplate to confirm product suitability for the application. If any doubts exist, contact Severn quoting the valve serial number.

### SCOPE OF THIS MANUAL - INSTALLATION

#### GENERAL

This manual includes installation, operating, and maintenance information for Globe and Angle body valves. Please refer to separate manuals for instructions covering the actuator, positioner, and any accessories. Where the valve is operated by electric, hydraulic, or electro-hydraulic actuation, follow the IOM instructions provided with the actuator.

Only persons qualified through training and or experience should install, operate, and maintain this product. In case of questions about these instructions or the valves please contact the nearest Severn office before proceeding.

Instructions in the following paragraphs describe the installation procedures for the control valve. Instructions not included are to be performed in accordance with standard industry-acceptable practices as may be required by local codes, specifications, and or regulations.

Users should refer to BS 6683 "Guide to installation and use of valves".

#### STORAGE

Unless specifically specified by the contract, the valve will have been packed for indoor storage at job site.

For short term storage the valve should be installed in a fire- resistant weather tight and well-ventilated building. The valve should be kept at a temperature of -20F (-29deg.C) to +120F (48deg.C). The area should be constructed and situated so that it will not be subjected to flooding; the floor should be similarly level, firm, protected and well drained. Valves should be on pallets or shoring to permit air circulation.

For longer storage, a corrosion preventative should be

considered that is compatible with the process fluids. Further advice should be sought from Severn.

#### SPARE PARTS

It is highly recommended that original parts from the manufacturer be used for servicing Severn.

#### UNPACKING

The valve may contain some important accessories and delicate components such as pressure gauges.

Care must be exercised when unpacking the valve to prevent damage to the accessories and component parts.

#### HANDLING

Applicable codes regulations and industry practices must be followed when handling or lifting valves. Care should be exercised to protect instrumentation and ancillary equipment. Severn lifting guidelines are available on request.

**Note:** Lifting should not be attempted except via designated lifting points or appropriate slinging of the valve. Other features such as manufacturing alignment or pressure test threading, where present, e.g. on block bodies, should not be used for lifting as they are not designed for this purpose.

#### FLUSHING

The control valve will have been cleaned at the factory and sealed for dispatch with protective covers. However, before installing the control valve, inspect the control valve body cavity to ensure it is free of foreign matter, dirt, grit, etc.

When the valve is to be installed in a system suspected to be contaminated the system should be flushed to prevent damage to the control valve trim. It is recommended this be done before installation of the valve or if not possible; special flushing trims should be purchased from Severn.

#### INSTALLATION

The control valve should preferably be installed in a straight run of pipe away from bends or sections of abnormal velocity and in accordance with general ISA guidelines. The preferred orientation is with the actuator vertically above or below the valve body. Other

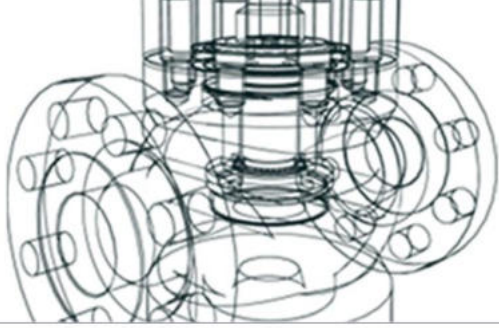

## Installation, Operation Maintenance Instructions for 1600 Series Globe Control Valve

orientations may be used but these may require support to be provided. An unsupported control valve may have a plug stem misalignment resulting in unacceptable hysteresis, seat leakage, and possible gland leakage. The weight of the control valve assembly should be taken into consideration when mounting in the pipework and pipe supports may be required either side of the control valve.

**Note:** Features such as manufacturing alignment or pressure test threading where present, e.g. on block bodies, are not designed for use as mounting points unless specifically authorized by Severn. The flow through the control valve must be in the direction as indicated by the flow arrow plate on the valve (damage to the trim, actuator and sudden movement of the valve may result from flowing in the wrong direction.) Use accepted piping practices when installing the valve.

Remove protective end caps or plugs and inspect valve end for damage on flange faces.

Thoroughly clean adjacent piping system to remove any foreign material that could cause damage to seating surfaces during valve operation.

Verify that the space available for installation is adequate to allow the valve to be installed and to be operated.

For pneumatic actuated valves, the Air Filter Regulator (AFR) supplied along with the valve should not be removed.

Care must be taken to avoid damage during the installation or disassembly.

Check to see that mating flanges are dimensionally compatible with the flanges on the choke and ensure sealing surfaces are free of debris.

Install the correct stud nuts for the application and place the flange gasket/rings between the flange facings.

### PRE-OPERATION

The valve gland was tightened before shipment; however, the packing may require some adjustment to meet specific service conditions before putting into service. It is normal to expect adjustments to be made prior to putting it into service. Connect the correct utilities to the valve and check all accessories, e.g., positioner, etc. are correctly set. The positioner must be set to close and seat the valve correctly to avoid any premature trim degradation. If a manual hand-wheel override is provided in the actuation system, ensure this is in the disengaged or neutral

position. Clean the actuator shaft of any foreign matter.

Check bonnet bolting in case of loosening. Re-check after the first heat cycle. Tighten evenly by going from opposite bolt to opposite bolt using the torques given within this manual on page 4 and in line with the recommendations as laid out for tightening sequence patterns in ASME PCC-1-2010, appendix F. Caution: Always use correct tools for bolting including the use of torque wrenches to assure bolts are not over tightened during any checks carried out.

### OPERATION

In operation, ensure that the valve operates smoothly and that there is no juddering or unusual motion. If the valve exhibits any strange behavior, please contact your nearest Severn representative immediately.

#### Important

For all actuator adjustments refer to relative IOM instructions. If any doubts exist, contact Severn quoting the valve serial number.

### QUICK-CHECK

1. Subject the valve to the full Stroke length and ensure the pointer in the valve indicates the correct stroke length in the travel indicator plate. The plug should have a smooth linear motion.  
**Note:** If graphite packing, the plug might provide a jerky movement due to friction ensure to lubricate the packing for smooth movement.
2. Ensure appropriate working of the positioner by subjecting the valve set up to various positioner ranges like (4-20 mA).
3. Ensure leak-free connections. Ensure proper tightening of the bolts and all-important connections.  
**Caution: Over-tightening of packing causes excess wear and high stem friction that may cause damage to the plug.**
4. Ensure the valve closes/opens in the correct direction according to the actuator and the flow direction.
5. Retightening of the flange ends is done to make sure the bonnet gaskets do not leak.
6. Ensure the actuator fail position is attained as required.
7. Ensure bonnet extensions for hot/cold service applications are not insulated.
8. Fit the body nuts and finger-tighten down all the bolts evenly around the bonnet flange.
9. Ensure concentricity, free movement of the plug, and orientation of the alignments before final tightening.

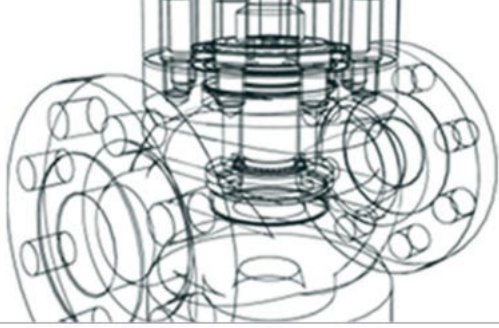

## Installation, Operation Maintenance Instructions for 1600 Series Globe Control Valve

10. Fully tighten the body nuts alternately using a cross-circular pattern with a 25 ft/lb torque wrench. Follow the required steps until the correct bolt torque loading is reached. Refer to torque values in Table 4 & 5.

**Note:** Ensure free up and down movement of the plug and proper seating of the plug onto the seat.

### MAINTENANCE

Control valve parts are subject to normal wear and tear and must be inspected and replaced as necessary. Inspection and maintenance frequency depends upon the severity and importance of the service. This section covers instructions for gland packing maintenance only. This can be carried out with the control valve in the line.

Whenever a valve is disassembled, it is mandatory that all consumable parts are replaced before re-assembly. Consumable parts are considered as all soft parts with the addition of the metal seal if used in place of a body gasket.

Severn takes great care in its selection and quality control in meeting all manufacturing requirements (heat treatment, dimensional tolerances etc.). Use only genuine replacement parts supplied by Severn.

### Screwed Seat Replacement

Screwed seat shall be dis-assembled with seat tightening tools listed below.

**Table 2: Screwed Seat Torque and Tooling**

Valve Size	Tightening Torque		Tool No.	Socket Size
	Nm	lbf-in		
1	28	248	2N33001/01	7/8"
1.5	46	407	2N33001/02	
2	69	611	2N33001/03	
3	130	1151	2N33001/04	
4	210	1859	2N33001/05	
6	338	2992	2N33001/06	

1. Use appropriate socket as per table-2 on torque wrench / torque gun.

2. Make sure that the seat tightening tool seats on the male projections of seat ring before applying torque.

3. Remove the seat ring and seat gasket from valve body.

4. Inspect the seat ring and body seat thread for wear or damage to ensure proper function after replacement.

5. Before installing new seat, clean the seat and body port thread. Apply suitable lubricant to seat and body port thread.

6. Insert the gasket on the screwed seat serrated mating surface at bottom.

7. Insert the seat into body and hand tighten to ensure proper mating to valve body.

8. Repeat step 1 & 2 and set appropriate torque on the torque wrench / gun as per table-2 and apply torque.



**Fig.2 Seat Tightening Tool**

### Plug+Stem Replacement

1. For replacing plug+stem assembly, complete the required actions stated in warning (page-2) and gland packing disassembly guidelines as stated later in this manual.

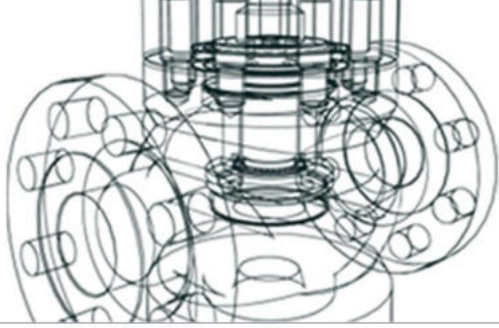

## Installation, Operation Maintenance Instructions for 1600 Series Globe Control Valve

2. For installing new plug+stem assembly, ensure the orientation is as per figure-2 for ensuring rated CV during operation. This orientation is applicable for Ported Cage Plug and Drilled Hole Plug types only. (Refer catalogue for trim types) Make sure the direction mark provided on top of the plug head facing towards the flow over direction of valve body as below during assembly.

4. After finishing plug assembly insert the bonnet spacer followed by packing and bolting assembly as stated later in this manual.

**Warning:** During actuator coupling do not rotate the valve plug stem as it will change the orientation maintained in step 3.

**Figure 2: Plug+Stem Orientation during installation**

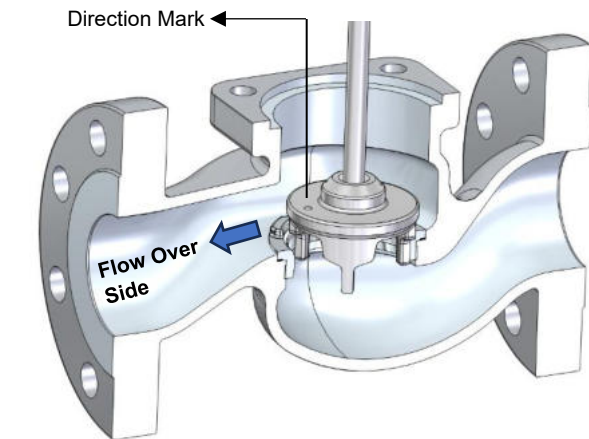

**Top View**

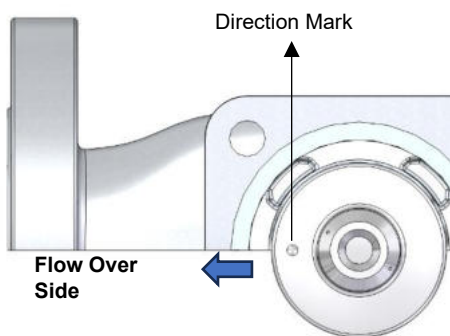

### RECOMMENDED SPARE

**Table 3: Spare parts for Valve**

S.no	Description	Quantity
1	Body Gasket	1
2	Seat Gasket	1
3	Packing Spacer	1
4	Balance seal*	1
5	Packing Washer	1
6	Gland packing Set	1
8	Soft Seat**	1

**Note:** \*if the valve is balanced  
\*\* If the valve with soft seat

**Table 4: Gland Packing torque values (PTFE)\***

Gland Follower Thread Size	Stem Dia	Recommended Packing Torque			
		Min. Torque		Max. Torque	
		Nm	lbf-in	NM	lbf-in
1"	0.5	25	221	63	558
1-3/8"	0.75	76	673	186	1646
1.75"	1.06	149	1319	313	2770

**Note:** \*Not Applicable for High Integrity PTFE Packing. Only PTFE

**Table 5: Gland Packing torque values (Graphite)**

Gland Follower Thread Size	Stem Dia	Recommended Packing Torque			
		Min. Torque		Max. Torque	
		Nm	lbf-in	NM	lbf-in
1"	0.5	49	434	63	558
1-3/8"	0.75	151	1336	186	1646
1.75"	1.06	255	2257	313	2770

### Gland Packing Maintenance

(this section not applicable to PTFE type, which does not require tightening)

A minor leak in the gland packing may be stopped by adjustment of the Gland follower. Take care not to overtighten as this may provide excess friction and could reduce valve performance.

If the gland packing is relatively new and tight on the valve stem and tightening the gland follower does not stop the leakage, the valve stem or the bonnet housing may be worn or scratched. Replacement packing should be

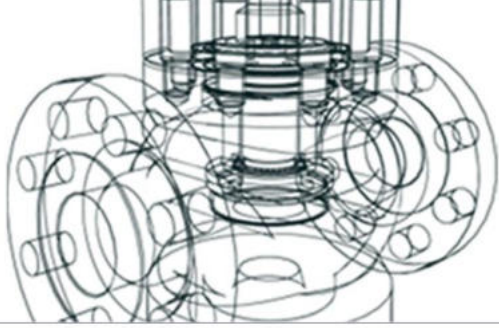

## Installation, Operation Maintenance Instructions for 1600 Series Globe Control Valve

considered with examination of the valve plug stem and bonnet bore.

Packing box maintenance may be performed as a part of major disassembly and repair or as a separate routine with the valve installed in the process line. In either case the following steps should be closely adhered to, otherwise serious injury or equipment damage could result.

### REMOVING THE GLAND PACKING AND STEM GUIDES

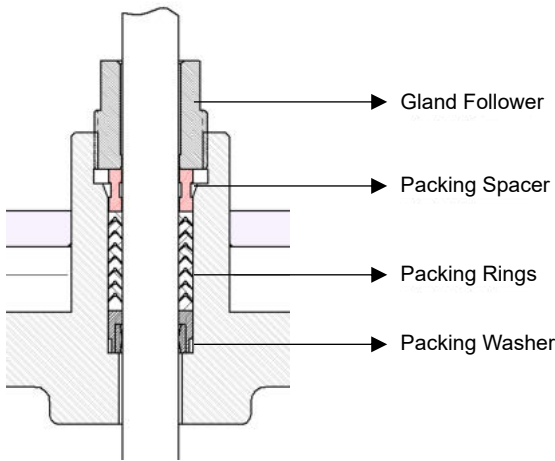

**Figure 3: Stuffing Box Components**

Ensure the valve is not pressurized. Remove the gland follower. Use Gland follower tightening tool from table-6 or suitable spanner to remove the follower. Remove gland packing. If the bonnet spacer is not removed from the valve, a packing extractor tool may be required to dig out the packing.

**Note:** If the new packing rings are solid endless rings (i.e.: PTFE, HIP, etc.), the actuator stem coupling will have to be disconnected. Refer to the actuator instructions for details of coupling removal.

Moving the plug up and down may also loosen the packing rings. If a packing extractor tool is used take great care not to damage any surfaces on the valve plug or the valve bonnet bore.

Clean the gland packing bonnet bore and other metal parts. Scratches and burrs that could cause gland leakage or damage to new parts must be removed by light emery cloth or if this does not remove the defect replace the damaged parts. Inspect the parts for wear or any other damage that would prevent proper operation

should these parts be reused. Gland packing and sealing gaskets should always be replaced with new, genuine Severn spare parts.

### STANDARD GLAND PACKING MATERIALS ASSEMBLY

Use the correct cross-section of gland packing or die-formed gland packing rings to fit the assembly. Install one ring of gland packing at a time. Make sure it is clean and has not picked up any dirt in handling. Seat each gland packing ring firmly (except PTFE filament and graphite yarn packing, which should be snugged up very gently, then tightened gradually after operating the valve a few full strokes).

Joints of successive rings should be staggered and kept at least 90 degrees apart. Each ring should be seated with a tamping tool or suitable split bushing to the gland stuffing box. After the last gland packing ring is installed, insert the packing spacer and then tighten the gland follower.

Do not jam the packing into place by excessive gland follower loading. Operate the valve a number of times to set the packing. Tighten the gland follower a little after each full cycle until no noticeable drop-off in bolt torque is noted.

For Graphite yarn gland packing, tighten the gland follower in small equal increments until an initial compression of the gland height of 30% is reached. For a 6 ring 0.15-inch uncompressed square packing set this would equal  $6 \times 0.15'' \times 0.3 = 0.27$  inch

Stroke the valve 3 to 5 full cycles and re-tighten as above.

### GRAPHITE LOW EMISSION FE GLAND PACKING SET

Install the gland packing set one ring at a time. A braided ring is fitted first followed by the shaped rings. Fit these rings in the correct direction with the top braided ring last. Compress the gland packing set to a distance of 1 packing cross-section. Check the torque on the gland follower to establish a reference torque. Actuate the valve plug stem in 3 or 4 full strokes. Check the gland follower torque and restore it to the original reference value. Repeat the full stroke and re-torque steps above at least 5 times until no significant amount of gland follower torque decay is noted after valve stem actuation.

**Note:** This information should be used as a guide only as

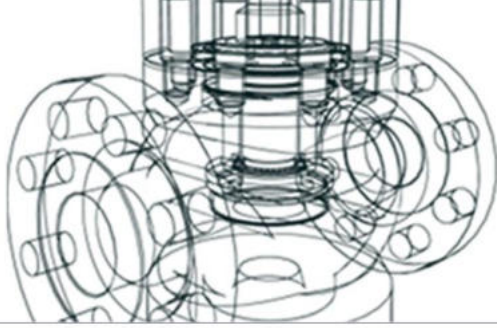

## Installation, Operation Maintenance Instructions for 1600 Series Globe Control Valve

each manufacturer of gland packing has its own specific installation instructions that should be followed. For other gland packing types see individual specialized packing instructions.

### BODY TO BONNET BOLT TORQUE SETTING STANDARD BOLTING

<sup>C S N</sup> Alloy Steel NACE Bolting (Torque to induce 30 ksi)<sup>CS</sup>

Alloy Steel Bolting. (Torque to induce 37.5 ksi)

<sup>S</sup>Aust. Stainless Bolting (Torque to induce 28.2 ksi)

**Table 6: Bonnet bolting torque values**

**Note:** Torque tolerance  $\pm 5\%$

Alloy Steel Bolting <sup>C S N</sup> NACE		Alloy Steel Bolting <sup>CS</sup>		Aust Stainless Steel Bolting <sup>SS</sup>		
Stud size & TPI	Nut Torque		Nut Torque		Nut Torque	
	ft/lb	NM	ft/lb	NM	ft/lb	NM
1/2-13	30	41	34	46	28	39
5/8-11	60	81	67	91	56	76
3/4-10	100	136	119	161	94	128
7/8-9	160	217	193	262	150	204
1-8	245	332	288	391	230	312
1 1/8-8	355	481	430	583	334	452
1 1/4-8	500	678	599	813	470	637
1 3/8-8	680	922	815	1105	639	867
1 1/2-8	800	1085	1080	1465	752	1020
1 5/8-8	1100	1491	1394	1890	1034	1402
1 3/4-8	1500	2033	1765	2393	1410	1911
1 7/8-8	2000	2711	2196	2978	1880	2548
2-8	2200	2983	2693	3651	2038	2804

**Note:** When bolting is Hot dipped galvanized (alloy steel bolting) or Fluoropolymer / Fluorocarbon carbon coated the values above should be reduced by approximately 25% of above.

**Note:** For bolting sizes, thread types and/or materials not listed seek advice.

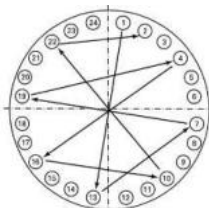

**24-bolt example of tightening sequence as per ASME PCC-1- 2010, Appendix F**

### ENVIROMENTAL LEGISLATION & IPPC DIRECTIVE 2008/1/EC

All companies have an impact on the environment and as such are morally and legally responsible for managing these effects. Environment legislation has been developed over the years to ensure that any impact stays within acceptable limits this legislation tends to be complex and constantly changing.

The European Union defines the obligations with which highly polluting industrial and agricultural activities must comply. There are now a number of EU Directives of direct relevance. The Integrated Pollution Prevention and Control (IPPC) Directive 2008/1/EC establishes a procedure for authorizing these activities and sets minimum requirements to be included in all permits, it requires the Best Available Techniques (BAT) for minimizing pollution for various industries. Be also aware of the European Pollutant Emission Register (EPER) under the umbrella of the IPPC Directive which may also impact the operation of the product.

Control valves permanently installed by professionals in large-scale stationary industrial machines or systems consisting of a combination of equipment/or components, each of which is manufactured to be used in industry only, are explicitly excluded from the scope (Article 2) of the Directive.

2012/19/EU (WEEE). They are consequently also excluded from the scope (Article 2) of Directive 2011/65/EU (RoHS).

### WARNING: HEALTH & SAFETY AT WORK ACT

**Gland packing and/or internal seals made of or containing PTFE (Polytetrafluoroethylene) should not be incinerated. Do not smoke whilst handling PTFE. Disposal**

Unless otherwise stated in the Installation and Maintenance Instructions, this product is recyclable, and no ecological hazard is anticipated with its disposal providing due care is taken.

### DISPOSAL

Unless otherwise stated in the Installation and Maintenance Instructions, this product is recyclable, and no ecological hazard is anticipated with its disposal providing due care is taken.

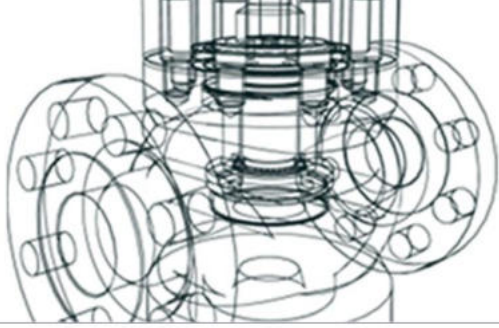

## Installation, Operation Maintenance Instructions for 1600 Series Globe Control Valve

### RETURNING PRODUCTS

Customers are reminded that under EC Health, Safety and Environment Law when returning products to Severn, they must provide information on any hazards and the precautions to be taken due to contamination residues or mechanical damage which may present a health, safety or environmental risk. This information must be provided in writing including Health and Safety data sheets relating to any substances identified as hazardous or potentially hazardous.

**Note:** This manual is to be read in conjunction with Severn's "Supplementary Installation, Erection, Maintenance, and Operating Procedures" document number DS610, specific conditions of use (SCofU) any other related O&M instructions relating to any accessories fitted to the Valve.

If any other maintenance work is required, please contact an approved service center for a quotation.

**Disclaimer:** Neither Severn or any of its affiliated entities assumes responsibility for the selection, use, or maintenance of any product.

Responsibility for the proper selection, use, and maintenance of any product remains solely with the purchaser and the end user.

The content of this publication is presented for information purposes only, and while every effort has been made to ensure accuracy, they are not to be construed as warranties or guarantees, express or implied, regarding the products or services described herein on their use or applicability. We reserve the right to modify or improve the designs or specifications of such products at any time without notice.

### SEVERN CONTACT DETAILS

**Severn Glocon Valves PVT Limited (Unit 1)**  
F96/97, SIPCOT Industrial Park,  
Irungattukottai, Chennai:602117, India  
T: +91(0)44 67102300 / 67102800

**Severn Glocon Valves PVT Limited (Unit 2)**  
A-50, SIPCOT Industrial Growth Center,  
Oragadam, Chennai:602105, India  
T: +91(0) 44 67123200

**Severn Glocon UK Valves Limited**  
Olympus Park, Quedgeley,  
Gloucester GL2 4NF, United Kingdom  
T: +44(0) 845 223 2040

**Centre of Engineering Excellence**  
Crossley Mills, Dean Clough, Halifax, HX3 5AX  
T: +44 (0)845 6070 710

**Severn Aberdeen**  
Unit E, Badentoy Avenue, Badentoy Park,  
Portlethen Aberdeen, AB12 4YB  
T: +44 (0) 1224 780 036

**Severn Qatar**  
Madina Group PO Box 24462  
Street No. 44/45, Salwa Industrial Area Doha, Qatar  
T: +971 (0) 4460 0818

E: [sales@severnvalve.com](mailto:sales@severnvalve.com)  
[marketing@severnvalve.com](mailto:marketing@severnvalve.com)

W: [www.severnvalve.com](http://www.severnvalve.com)

**Document Version:** 1600-1.0/10/2025