

Installation, Operation Maintenance Instructions for 'W' – Series Diaphragm Actuator

General Information

The purpose of this manual is to guide the process of unpacking, installation, and maintenance of Severn 'W' Series Pneumatic Linear Actuators. It is highly recommended that the users and personnel responsible for maintenance read this manual before proceeding to install, operate or perform any procedures on the actuator. Instructions as per the manual are followed to avoid mishaps and injuries.

Spare Parts

It is highly recommended that original parts from the manufacturer are used for servicing Severn Actuators.

USE OF THIS MANUAL, LEGAL DIRECTIVES, ENVIRONMENTAL AND OTHER SAFETY NOTICES

This manual to be read in conjunction with Severn "Supplementary Installation, Erection, Maintenance and Operating Procedures" documents and other related O & M instructions relating to accessories fitted to the Control Valve. All notices, warnings and guidance given in that manual are also applicable to this document.

INTENDED USE

Reference is to be made to the Control Valve Specification Sheet, Installation and Operation Instructions, nameplate to check product is suitable for the intended use / application.

See Installation, Operation and Maintenance Instructions for Severn Control and Choke valves information on the following (latest edition):

1. MACHINERY DIRECTIVE INCORPORATED INTO A MACHINE
2. ATEX DIRECTIVE
3. PRESSURE EQUIPMENT DIRECTIVE PED
4. ENVIROMENTAL and OTHER LEGISLATION & IPPC DIRECTIVE
5. RETURNING PRODUCTS

DISPOSAL

Unless otherwise stated in the Instructions, this product is recyclable, and no ecological hazard is anticipated with its disposal providing due care is taken

If any doubts exist, contact Severn quoting the valve serial number

Safety: Always ensure safe working practices are followed:



Always wear appropriate PPE and ensure that the local lifting plan is followed



Always ensure a safe working environment when lifting



Always isolate valve before maintenance. Always use lockout methods to ensure safety



Poison risk: Do not incinerate PTFE. Do not smoke whilst handling PTFE.



Caution: Do not put hands inside yoke area



Always use correct tools. Do not over tighten. Do not use extension bars to force movement



Always read the manual. If any doubts exist, contact SEVERN quoting the valve serial number.

WARNING: When ordered, the actuator and or control valve configuration and materials of construction are selected to meet particular pressure, temperature, pressure drop and controlled fluid conditions. Personal injury, property damage, equipment damage, or leakage due to escaping gas or bursting of pressure containing parts may result if the actuator and or control valve or its ancillaries are over pressured or installed where service conditions exceed the actuator and control valve design limits.

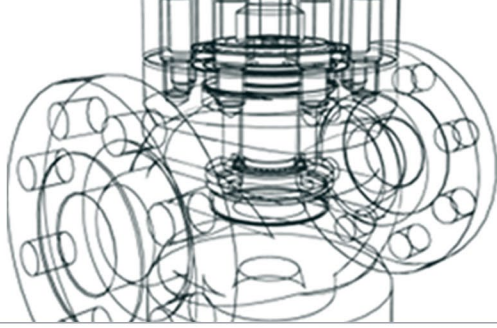

Installation, Operation Maintenance Instructions for 'W' – Series Diaphragm Actuator

To avoid such injury or damage, provide a relief valve for overpressure protection as required by accepted industry or local codes and good engineering practice. Do not apply other conditions to the valve without written approval from Severn.

WARNING: Before performing any maintenance operation: Isolate the actuator and or control valve from process pressure. Relieve process pressure from both sides of the control valve. Drain the process media from both sides of the valve. If the control valve is to be removed from the line decontaminate any process fluid remaining in the valve to make safe. Disconnect and isolate any operating lines providing air pressure, electric power, or a control signal to the actuator. Vent the air pressure from the actuator. Be sure that the actuator cannot suddenly open or close the valve (Note by disconnecting the air and or power lines the actuator will move the valve to its fail-safe position). Ensure persons are a suitable distance from moving parts.

Use lock out procedures to be certain that the above measures stay in effect whilst work is carried out on the actuator or control valve.

Scope of this Manual – Installation - General

This manual includes installation, operating and maintenance information for Severn W Series actuators only. Please refer to separate manuals for instructions covering the valve, positioner, and any accessories. Where the valve is operated by electric, hydraulic, or electrohydraulic actuation, follow the IOM instructions provided by the actuator manufacturer.

Only persons qualified through training and or experience should install, operate and maintain this product. In case of questions about these instructions or the valves please contact the nearest Severn office before proceeding.

Instructions in the following paragraphs describe the installation procedures for the actuator. Instructions not included are to be performed in accordance with standard industry acceptable practises as may be required by local codes, specifications and or regulations. Users should refer to BS 6683 "Guide to installation and use of valves".

Storage

Unless specifically specified by the contract, the actuator (or valve and actuator) are packed for indoor storage at job site.

For short term storage the actuator or valve and actuator, should be installed in a fire-resistant weather tight and well-ventilated building. The equipment should be kept at a temperature of –20F (-29deg.C) to +120F (48deg.C). The area should be constructed and situated so that it will not be subjected to flooding; the floor should be similarly level, firm, protected and well drained. Actuators and valves should be on pallets or shoring to permit air circulation.

For longer storage, a corrosion preventative should be considered that is compatible with the process fluids. Further advice should be sought from Severn.

Handling

Applicable codes regulations and industry practices must be followed when handling or lifting valves. Care should be exercised to protect instrumentation / ancillary equipment. Severn lifting guidelines are available on request.

Installation

Make sure adequate overhead clearance exists when installing the actuator. Minimum clearance is 150mm. It is usual to use the actuator with a suitable valve positioner. If this is the case, the air supply and instrument signal connections must be connected as per the positioner manufacturer's instructions.

WARNING: Do not exceed the recommended air supply pressure shown on the Severn specification sheet, as injury to personnel or damage to equipment may occur.

The use of an air filter regulator on the air supply line is recommended. Instrument quality air is required for operation of the actuator and any ancillaries fitted. The weight of the actuator valve assembly should be taken into consideration when mounting on to a valve. Supports may be required depending on the actuator orientation.

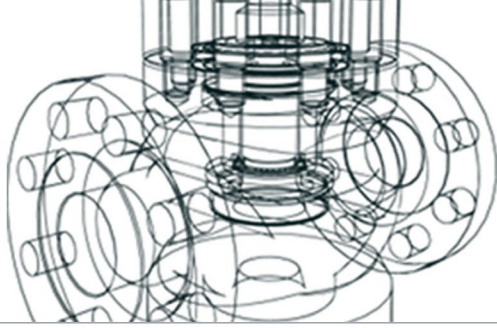

Installation, Operation Maintenance Instructions for 'W' – Series Diaphragm Actuator

Unpacking

1. The initial step in unpacking would be to cross verify the received materials against the packing list. A list containing the details of the actuator and accessories that are supplied along with every shipping container.
2. Ensure to lift the actuator from the packing box with utmost care and caution. Use of slings, lifting lugs is strictly recommended to position them precisely and not to damage the other mounted accessories.
3. Contact respective shipper if any fatal damage.
4. For further enquiries & assistance contact the manufacturer.

Installation

Warning: Ensure the air supply pressure does not exceed the maximum permissible design pressure of the actuator indicated on the respective label.

Caution: Ensure to provide adequate overhead space facilitating easy removal of the actuator from the set up.

1. The name plate has details about the air supply pressure, ensure to connect lines accordingly.
2. Facilitate overhead clearance of 200 mm for actuator of all sizes.
3. Utilize lifting straps for lifting the actuator. Make sure the actuator is supported at its centre of gravity.
4. Its highly recommended to have a Air Filter Regulator on the line.
5. Leak free connections are to be installed and inspected.
6. Go through the preventive measures mentioned in Table 3 before installation.

Quick-Check

1. Subject the actuator to the full Stroke length and ensure the specified fail position is attained.
2. The piston rod should have a smooth linear motion.

3. Ensure appropriate working of the positioner by subjecting the valve set up to various positioner ranges like (4-20 mA).
4. Ensure leak free connections. Ensure proper tightening of the bolts and all-important connections.
5. Ensure the fail open and close conditions of the actuator are attained.
6. Retightening of the tension nuts, nuts and bolts are done to make sure no leakage and proper rugged assembly.
7. Ensure the actuator fail position is attained as required.

Table 1: Overhead Clearance

Actuator Size	Max Pressure	Minimum Clearance
Size 38 in Sq. - H	60PSI	200 mm
Size 75 in Sq. – H	60 PSI	
Size 150 in Sq. – J	60 PSI	
Size 300 in Sq.– K	50 PSI	

Maintenance

Preventive measures are the primary steps for ensuring the proper working of the actuator on a periodic basis of 6 months.

The preventive measures are done without interrupting the service.

Caution: In case of internal Problem refer section “Actuator Disassembly and Reassembly”

The actuator is inspected for damage due to process drippings and hazardous fumes.

1. Entire valve-actuator package requires cleaning and repainting in case of severe oxidation.
2. Ensure to check proper functioning of the actuator by stroking the valve to the fully closed and open positions.

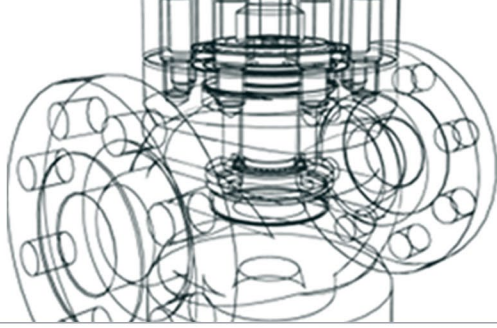

Installation, Operation Maintenance Instructions for 'W' – Series Diaphragm Actuator

Common Lubricants

Table 2: General Application Lubricants

Lubricant	Purpose
MOLYKOTE 55M	Used to lubricate Studs and Nuts
CASTROL SPHEEROL B2	Used for packed grease bearings and gearbox on side /top hand wheel units.
ROCOL- Anti-Seize	Designated to facilitate positive tightening and ease dismantling.
ROCOL- Dry PTFE Spray	Designed to give an almost invisible, dry film coating.
STAG	Sealing of screwed seats
LOCTITE	Nut lock 242 -Used as general-purpose thread locking Thread sealant 577- For sealing of pipe fittings and coarse threaded components

4. Fastening of the accessories, brackets, and other mounted parts to be checked more than once.
 5. Bolting of the actuator parts to be checked with caution. Ensure to maintain constant tightening torque throughout.
 6. Remove the air supply, observe and ensure the actuator attains the respective fail-safe position.
 7. Ensure the actuator stem is free from grit, dirt, and foreign material.
 8. If air filter regulator is present, ensure to check and replace cartridge whenever applicable.
- Note:** Refer to appropriate user manuals for respective positioner and accessories.
9. Ensure actuators fail safe position is attained by removal of air supply.
 10. Ensure the air filter regulator is checked, and the cartridge is replaced whenever required.

11. For ensuring no leak around the diaphragm region, bolting region and stem coupling region, spray soap solution around the region and observe for any leaks.
12. Remove air supply and check the actuator fail safe position is attained.
13. In case of actuators, spray soap solution or apply manually with brushes around the actuator diaphragm casing, actuator stem guide position and applicable positions to check for possible leaks.

Warning: When operating the valve, ensure body parts, clothing, etc. are kept away from all moving parts as it may lead to serious injuries.

14. Ensure to subject the valve to respective bolting torque values. Never over tighten the bolts it might cause friction and damage the plug stem.
15. Ensure to calibrate the entire actuator set up.
16. Ensure to lubricate the sealing parts & 'O' rings.

Actuator Removal from the Valve

The pneumatic actuators that are fixed on to the assembly is a spring and diaphragm actuator of varying sizes like 38 Sq. in, 75 Sq. in, 150 Sq. in or 300 Sq. in which consists of a bolted bonnet and split clamp coupling to the actuator stem connection. Refer Figure 1 and 2 for the coupling assembly.

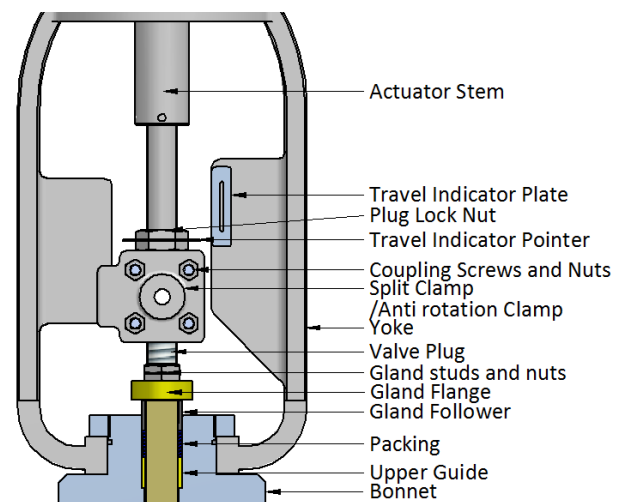
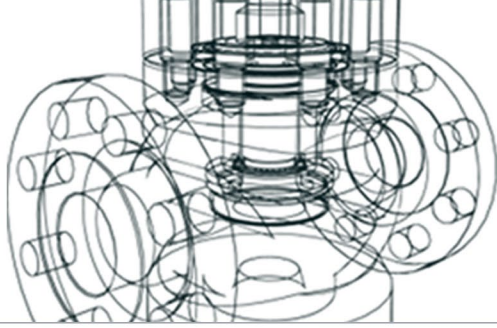

Figure 1: Bolted Bonnet & Split Clamp Actuator Stem Coupling



Installation, Operation Maintenance Instructions for 'W' – Series Diaphragm Actuator

Warning: Ensure the entire setup is depressurized and the respective process fluids are drained out before the disassembly of the valve to avoid serious injuries and mishaps.

Caution: Great care to be ensured while lifting the actuator off the valve to avoid possible damage that could be caused onto the valve plug stem and seat.

For any actuator the following steps must be followed:

1. For Air Fail Open (AFO) also known as direct acting spring actuators, the valve plug/actuator stem should be raised to open position of about 3mm by using an external air supply.
2. For Air Fail Close (AFC) also known as reverse acting spring actuators, pressurize the spring to close the valves entire stroke length by using an external pressure regulator which is installed in the line and connected to the lower air port connection in the Cover plate of the actuator.
3. Support the weight of the actuator by use of suitable slings.
4. The split clamp coupling screws and nuts are unscrewed of the coupling joint. Ensure to place the plug-in position with utmost care.
5. Respectively the gland flange set up is loosened and respectively the lock nut is removed too.

Note: The above procedure specifically for Severn globe valves. Refer respective valve manuals.

6. Ensure to cut the supply and remove it from the valve.
7. Slowly lift the actuator above the valve stem paying attention not to damage the actuator accessories.

Caution: Heavy actuators may require hoists to separate the actuator from the valve. Respective lifting lugs and eye bolts may be used if provided; else the valves are lifted along the yoke legs with slings and hoists around the yoke.

Actuator Disassembly and Reassembly

Warning: Ensure the entire setup is depressurized and the respective process fluids are drained out before the disassembly of the valve to avoid serious injuries and mishaps.

Actuator Disassembly

Steps to be followed for the disassembly of the actuators are as below. Refer fig 3 & 4.

1. Disconnect the tubing's and other accessories attached to the actuator.
2. Relieve all spring compression by loosening the spring adjusting screw. Remove the spring adjuster of the actuator to ensure the spring compression is relieved.
3. Based on type of valve attached to the actuator the respective manuals are followed for 'Actuator removal from the valve'

Warning: Spring compression should be relieved before any further disassembly to avoid any fatal mishaps and injuries.

4. After ensuring the spring is in the retracted state, the diaphragm case screws and nuts are loosened and removed. Respectively the upper diaphragm case is removed.

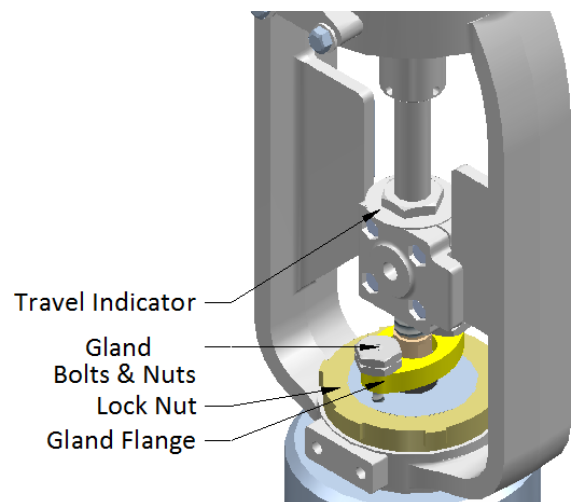
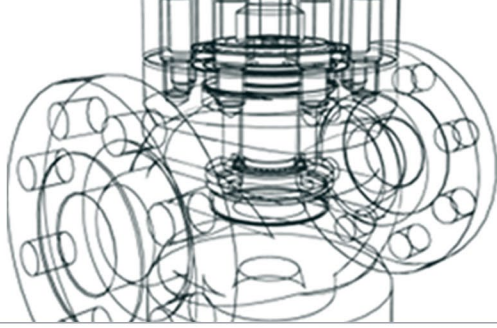

Figure 2: Detailed view of Gland Flange & Lock Nut



Installation, Operation Maintenance Instructions for 'W' – Series Diaphragm Actuator

- The removal of the diaphragm and actuator stem assembly is carried out in sequence. This assembly consists of the following components: Actuator Stem Diaphragm, Diaphragm Button Plate, Diaphragm Top Collar, Diaphragm Bottom Collar, Collar Nut.

These components are assembled precisely according to the fail-action position. The diaphragm is thoroughly inspected for any external damage, wear space.

- The spring, travel stop tube, spacer and the spring retainer are respectively removed from the assembly.
- The lower diaphragm casing is removed from the yoke by loosening the cap screws that holds it in place.
- For AFC the Cover plate is then separated from the yoke. The Cover plate assembly comprises of Cover plate, Sealing Box, O-Rings which are disassembled only if required. Ensure to replace the 'O' rings on the Cover plate and sealing box if required.

- Note:** The disassembly of all actuators G, H, J & K is similar except for AFC and AFO the diaphragm assembly is different refer respective figures, the yoke assembly comprises of a Cover plate on top of the yoke for AFC actuators. This emphasizes the need for special care to be taken while dismantling the Cover plate from the yoke.

Actuator Reassembly

Refer figures 3 & 4 for reassembling the actuator. Ensure to disconnect air piping from diaphragm case.

- Ensure to replace all the 'O' rings in the entire actuator assembly with new ones.
- Initially the parts are to be cleaned and lubricated with respective lubricants.
- Position the yoke tightly using a vice. Locate the spring, spring retainer and travel stop on to the yoke set up.
- For AFC the Cover plate assembly is positioned on top of the yoke. The Cover plate assembly comprises of Cover plate, sealing box and 'O' – Rings. Cover plate 'O'- Rings and Sealing box 'O'- rings are replaced with new ones and respectively assembled. The tight fit of sealing box in the bore is ensured to avoid leaks and flaws in the actuator.

- For AFO the lower diaphragm casing is directly positioned on to the yoke while in AFC the lower diaphragm casing is positioned on top of the Cover plate assembly. The lower diaphragm casing is positioned tightly using respective Cap screws.
- For AFO the lower diaphragm casing is directly positioned on to the yoke while in AFC the lower diaphragm casing is positioned on top of the Cover plate assembly. The lower diaphragm casing is positioned tightly using respective Cap screws.
- Respectively for both AFO and AFC the diaphragm stem set up is positioned on to the lower diaphragm casing positioning the diaphragm to accurate position ensuring no damage being caused to it.

Note: The Diaphragm – Stem assembly is different for both AFO and AFC and is represented specifically in figure 3 & 4.

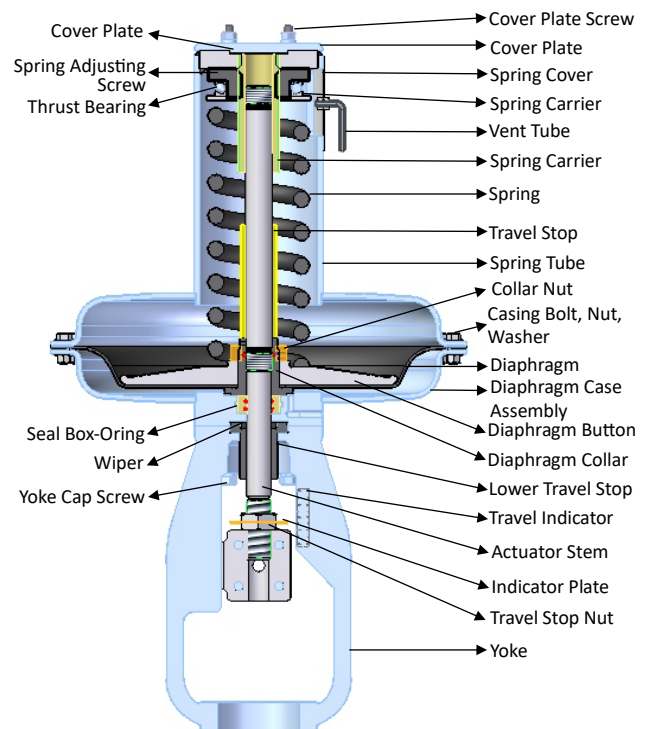
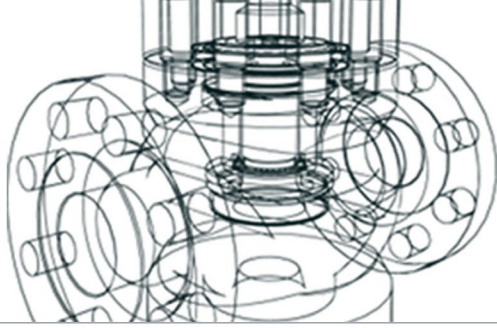

Figure 3: Severn Glocon 'W' Series Reverse Acting (AFC) Actuator – Cross Sectional View



Installation, Operation Maintenance Instructions for 'W' – Series Diaphragm Actuator

8. The upper casing is then properly positioned ensuring a perfect sealing between the lower casing, diaphragm, and the upper casing. They are then held together and tightened using bolts, nuts, and washers in a cross-circular pattern which in turn provide tight sealing.
9. After proper positioning of the casings & diaphragm ensure no leak is formed in the sealing region using soap water if any leakage.

The above steps are to be repeated till there is no leakage.

10. After ensuring perfection in the diaphragm region the spring retainer is to be properly positioned using thrust bearings which are placed on to the bore provided on the spring retainer from underneath and tightened by screwing the thrust bearing into its position.

Side Mounted and Top Mounted Handwheel Advanced Maintenance

For Top/Side-mounted, continuously connected hand-wheel checking for general condition is required. However, disassembly may be necessary if the mechanism fails. When reassembling the handwheel, be sure to clean and lubricate the screw and drive nut with a multi-purpose grease (Refer figures 5 & 6 for arrangement)

IMPORTANT: After operation of the override, it must be returned to the neutral position for automatic operation (shown by manual override indicator in the window of screw housing tube).

Operation

If a pneumatic failure occurs, or if manual control of the valve is desired, the unit can be operated as follows:

1. Set the three-way bypass valve (located on the pneumatic supply line to positioner) to 'Hand' to vent the air pressure from the actuator.

Note: A three-way valve is installed in the supply line only when there is no lock-up system or volume tank. On volume tank or lock-in place systems, the bypass valve is located between the top and bottom ports. However, on some pneumatic circuits the single three-way bypass valve may be substituted by two two-way manual valves. Consult the pneumatic circuit supplied with the actuator documentation.

WARNING: By venting the air, the actuator will move to the failsafe position, this may be fast. Please keep away from moving parts including the positioner linkage to avoid injury.

2. To open the valve, turn the hand-wheel counter-clockwise to retract the plug. To close the valve, turn the hand-wheel clockwise to extend the plug.

3. To return the valve to automatic control, return the hand-wheel indicator to the neutral position and set the three-way bypass valve (see previous NOTE) to 'Auto'.

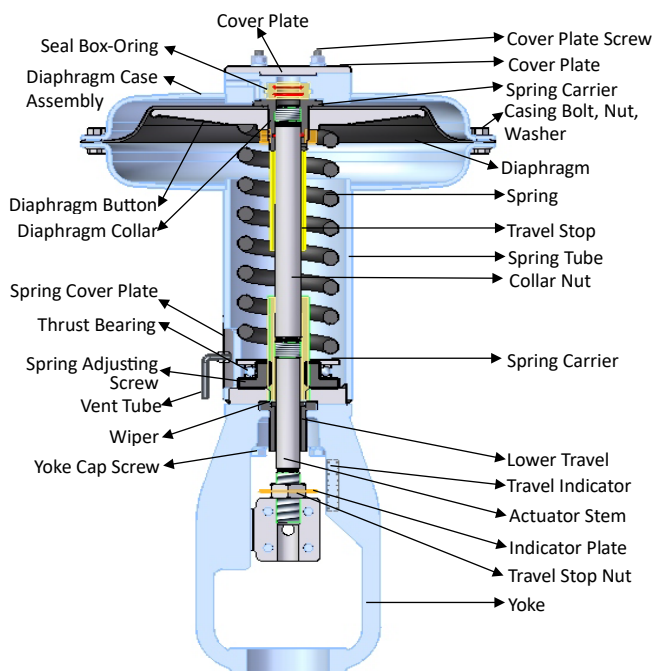
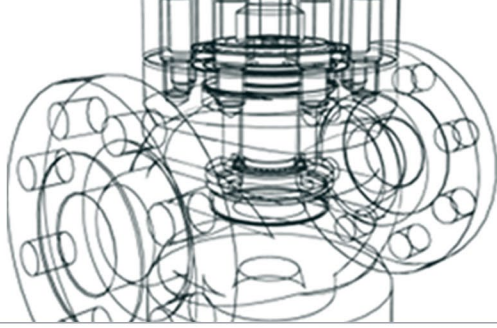

Figure 4: Severn Glocon 'W' Series Direct Acting (AFO) Actuator – Cross Sectional View



Installation, Operation Maintenance Instructions for 'W' – Series Diaphragm Actuator

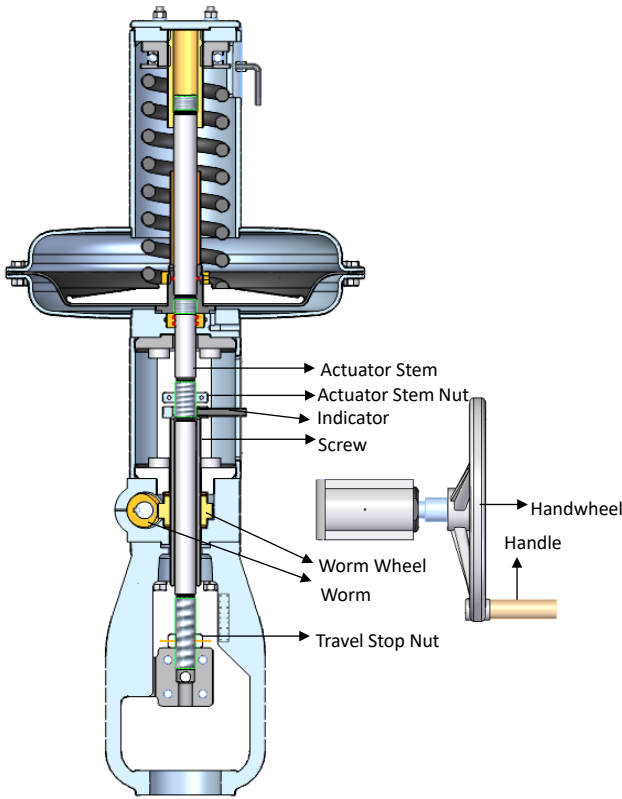

Figure 5: Actuator Cross Sectional View
(AFC with Side Mounted Handwheel
Sizes 75, 150 and 300 Sq. inch)

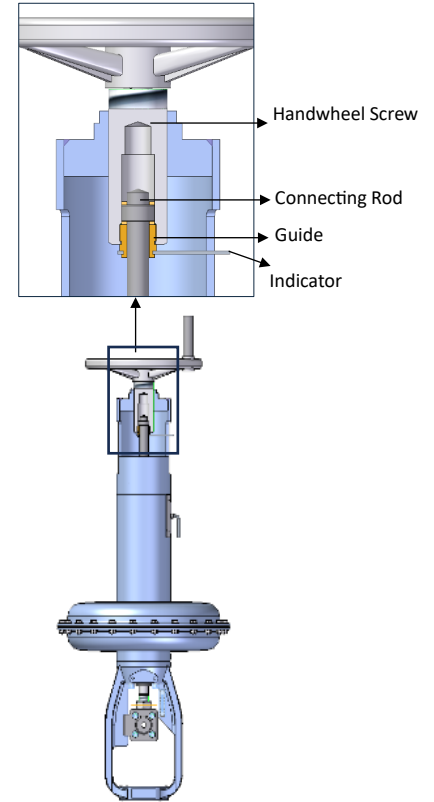
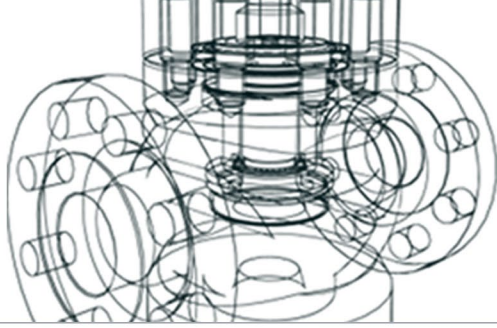

Figure 6: Actuator Cross Sectional View
(AFC with Top Mounted Handwheel
Sizes 38 Sq. inch)

Table 3: Actuator Troubleshooting

Problem & troubleshoot	Possible Cause	Corrective Action	Preventive Measure
Drastic Increase in Air Consumption & Leakage	Instrumentation Leak	Retightening of connections to be done.	Before installation all lines to be tightened
	Positioner Malfunction	Positioner maintenance to be done.	Respective positioner maintenance and preventive measure to be followed.
	Gasket /O-ring Leakage	Replace O- rings/Gaskets.	Ensure no leak through gaskets and O-rings before installation.
Air Fail Position Unacquirable	Air in cylinder is not exhausting/ Positioner Fault	Positioner maintenance to be done.	Respective positioner maintenance and preventive measure to be followed.
	Spring Failure	Based on application replace spring.	Spring in actuator to be crosschecked with specification sheet.
	Valve Internal Problem	Respective Valve troubleshoots to be referred.	Valve maintenance to be done before disassembly of actuator.



Installation, Operation Maintenance Instructions for 'W' – Series Diaphragm Actuator

Stem Travel Is Unsmooth & Jerky	Deficient Air Supply Pressure	Air supply and filter regulators to be checked. Leakage of O-rings to be verified.	Supply pressure through lines and accessories to be verified before installation. Ensure no leak through gaskets and O-rings before installation.
	Lubrication Deficiency	Lubricate thrust bearing and respective areas.	Ensure bearings & walls are lubricated.
	Damaged Guides & Bushes	Actuator stem & Guides replaced if damaged.	To be assembled in such a way minimal scoring occurs.
	Wrong Spring Assembly	Refer "Reassembly of Actuator".	Smooth movement of actuator stem to be checked before assembly.
	Valve Internal Problem	Respective Valve troubleshoots to be referred.	Valve maintenance to be done before disassembly of actuator.

SEVERN CONTACT DETAILS

Severn Glocon Valves PVT Limited (Unit 1)

F96/97, SIPCOT Industrial Park,
Irungattukottai, Chennai:602117, India
T: +91(0)44 67102300 / 67102800

Severn Glocon Valves PVT Limited (Unit 2)

A-50, SIPCOT Industrial Growth Center,
Oragadam, Chennai:602105, India
T: +91(0) 44 67123200

Severn Glocon UK Valves Limited

Olympus Park, Quedgeley,
Gloucester GL2 4NF, United Kingdom
T: +44(0) 845 223 2040

Centre of Engineering Excellence

Crossley Mills, Dean Clough, Halifax, HX3 5AX
T: +44 (0)845 6070 710

Severn Aberdeen

Unit E, Badentoy Avenue, Badentoy Park,
Portlethen Aberdeen, AB12 4YB
T: +44 (0) 1224 780 036

Severn Qatar

Madina Group PO Box 24462
Street No. 44/45, Salwa Industrial Area Doha, Qatar
T: +971 (0) 4460 0818

E: sales@severnvalve.com
marketing@severnvalve.com

W: www.severnvalve.com

Document Version: W Series Actuator -1.1/03/2025