

1200 Series Globe Valves

Pressure Class ASME 150-600

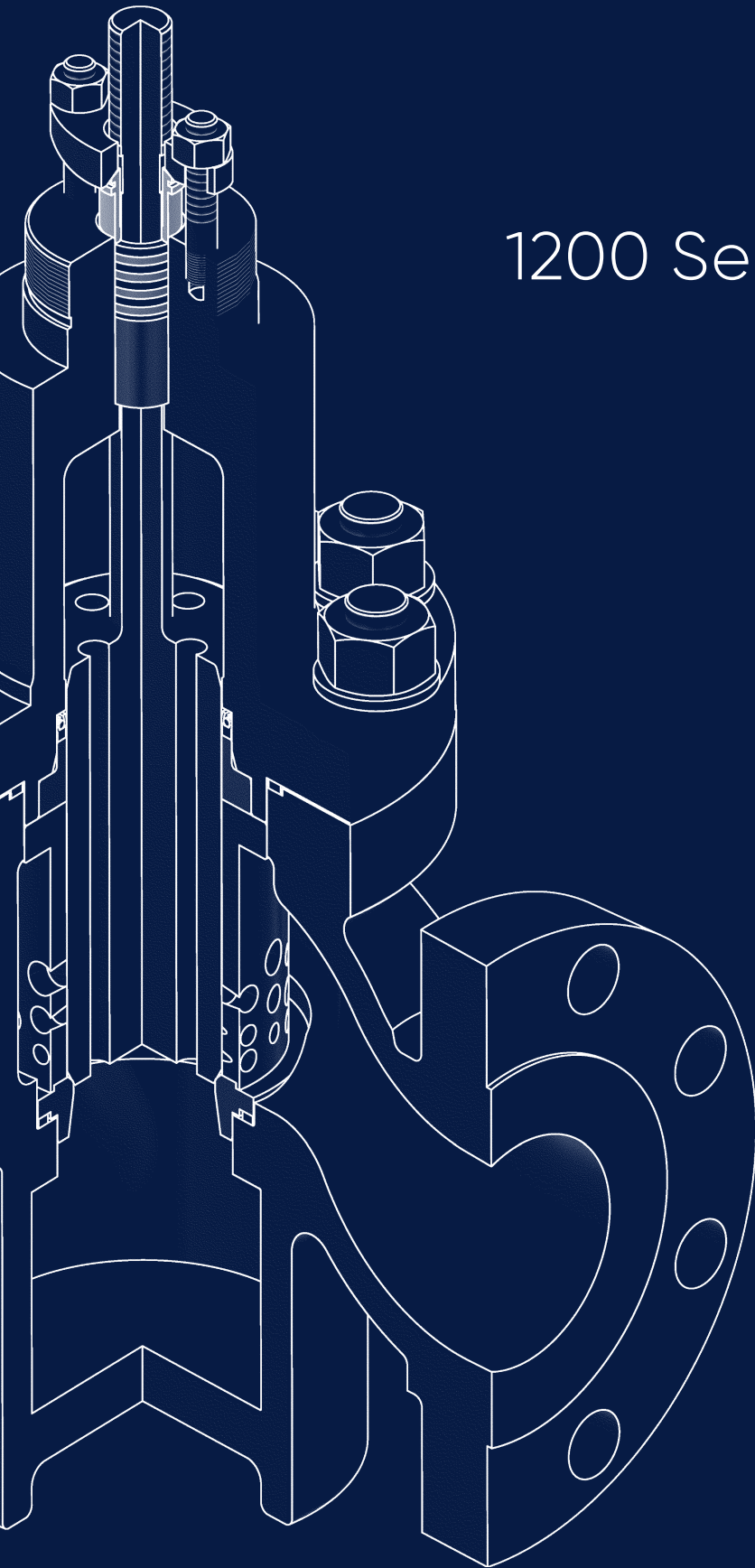

It all flows from expertise.



Engineering
Excellence

Contents

1200 Series: Introduction	1
Valve Model Numbering	2
Engineering data	3
Valve components	4-5
Body and bonnet options	5
Trim options	6-8
Gland packing options	9
Flow Coefficients, Cv	10-12
Dimensions and weights	13

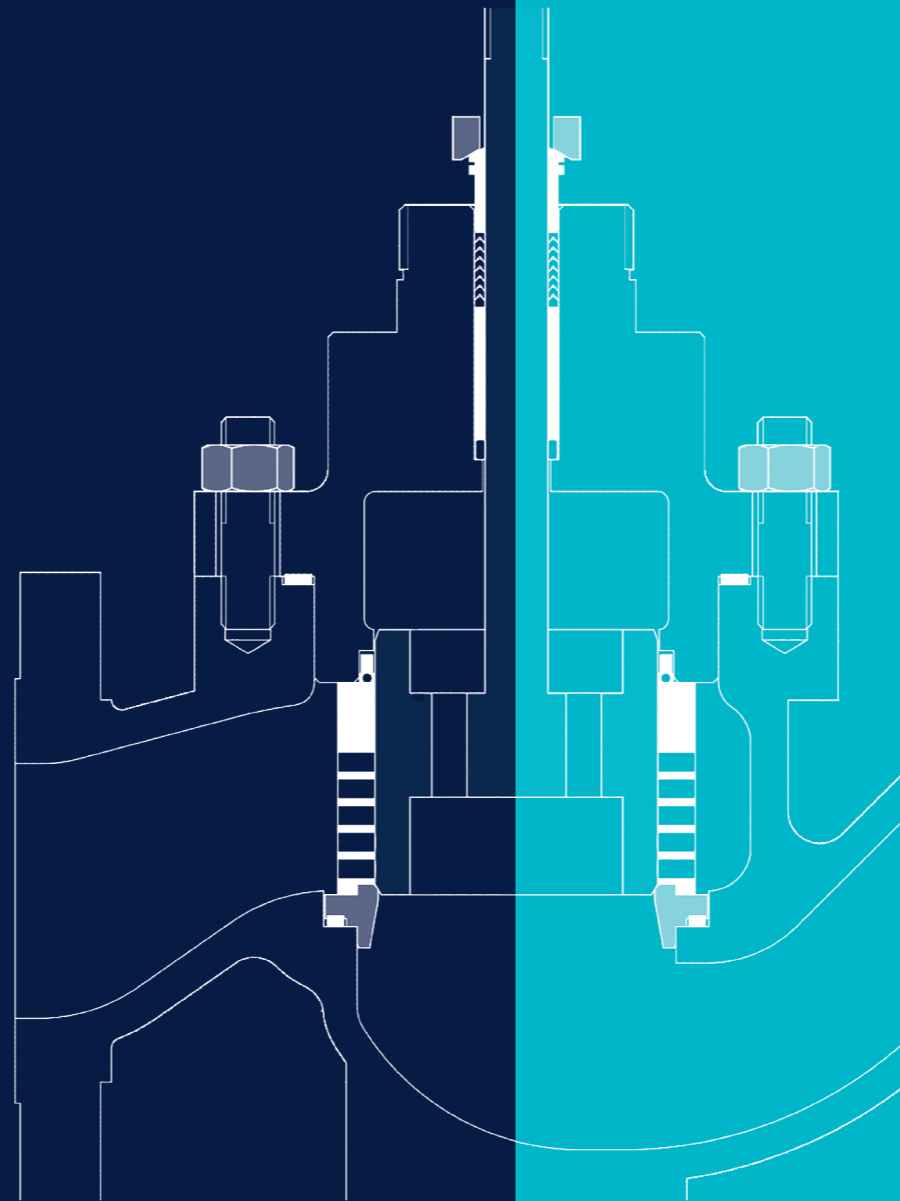

1200 SERIES

The 1200 Series Globe Control Valve is designed to exceed the expectations of Hydrocarbon and similar industry application. Higher flow capacity, durable shut-off, low emission, NACE conforming material options, reduced overall dimension and weight are the hallmarks of this design.

The unique static balance seal with clamped seat, minimized use of shims / gaskets, large post/cage guiding ensures ruggedness and durability.

Standardized components and interchangeability across sizes, ratings and trim options enable less inventory and spares, paving way for stock holding and shorter lead times. The product is designed for ease in manufacturing, assembly, operation and maintenance.



Valve Model Numbering

This series cover valves from size 1 inch to 12 inch and pressure class ASME 150 to 600. It also offers versatile trim characteristics and Cv options. It is multipurpose and suitable for cavitating / flashing applications or noise service.

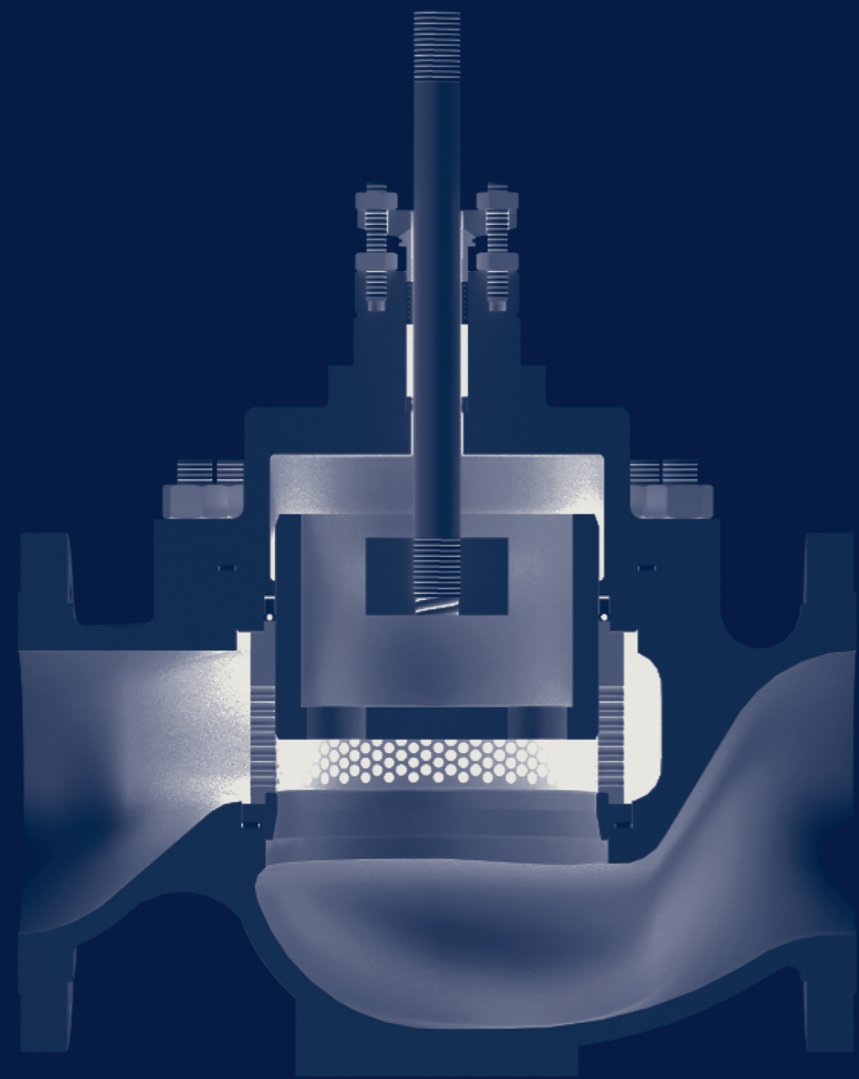
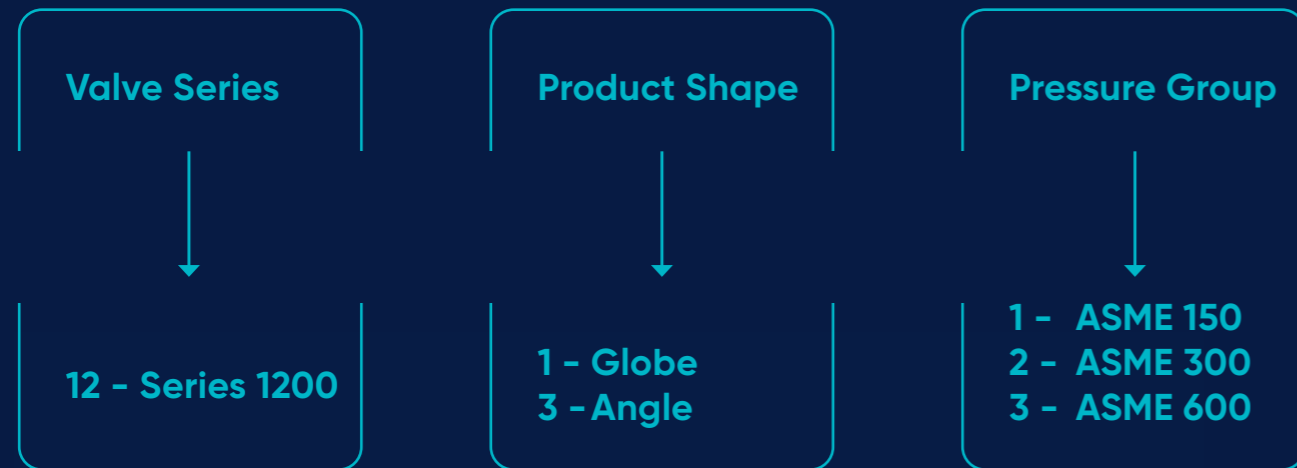

Engineering data

Model

1200 Series Globe Valve

Sizes

1 inch - 12 inch

Design Standard

ASME B16.34

Face to Face

ISA 75.08 / IEC 60534-3-1

Body Style

2-way Globe straight
Angle Body

Body Material

Wide ranging options including;
WCB / WCC, LCB / LCC,
CF8M, CF3M, Duplex Gr.4A and Super duplex Gr.6A.

Pressure Class

ASME 150 - 600

End Connection

Integral flanged (RF/FF), ASME B16.5
Butt Weld End, ASME B16.25
Socket Weld End, ASME B16.11

End Finish

125-250 AARH & 63-125 AARH

Bonnet Styles

Standard
Extended
Available in unbalanced and balanced configuration depending on the valve size and pressure class.

Gland Packing

PTFE Chevrons
Graphite
High integrity packing

Body / Bonnet bolting

Valve Material	Non Sour Service		Sour Service (NACE MR0175)	
	Stud	Nut	Stud	Nut
CS	B7	2H	B7M	2HM
LT. CS	L7	7L	L7M	7ML
SS / DSS	B8M	8M	B8M	8MA

Gaskets

316L spiral wound gaskets with graphite filler, standard. 32760 spiral wound gaskets with graphite filler, optional.

Trim Options

The trims are designed for easy assembly and maintenance. The "Clamped Seat - Quick change design" of 1200 series requires no special tooling for assembly and maintenance.

The Series offers the following trim styles

Micro spline
Contoured
Ported cage
Concentric cages 1CC and 2CC

1CC ported cages – unbalanced and balanced configuration.
2CC cages – balanced configuration.
In concentric cages, flow under is suited for aerodynamic noise control service and flow over is suited for cavitating and flashing service.

Inherent Trim Characteristics

Equal percentage
Linear
Quick opening
Bi-Linear

Guiding

Ported / Cage / Top guided.

Balance seal options

Spring energized PTFE lip seal (-196°C to 232°C)
Graphite laminates w/ scrapper rings (232°C to 427°C)

Hard facing

Wide ranging options available.
Refer Table 1 for suitable combinations
More options available on request.

Seat Leakage

ANSI / FCI 70.2 / IEC 60534-4 Class IV is standard
Class V with metal seat
Class VI with soft seat insert

NACE MR0175 and MR0103

The 1200 Series product design, characteristic and manufacturing process assures easy compliance of body, bonnet, trim and bolting material with the requirement of NACE MR0175 / ISO 15156 and MR0103.

Actuation*

W - Series, Spring + Diaphragm actuator
Hydraulic / Electric actuators
Manual actuators

Accessories

A wide range of control instruments are available from Severn, including : Positioners, Air-filter Regulators, Volume Boosters, Solenoid Valves, and Lock-up Valves.

*Flow coefficient and dimensional details of Globe valves offered with 'P Series' Actuators can be referred in 1200P catalogue - PLN/120P/3.07/01.

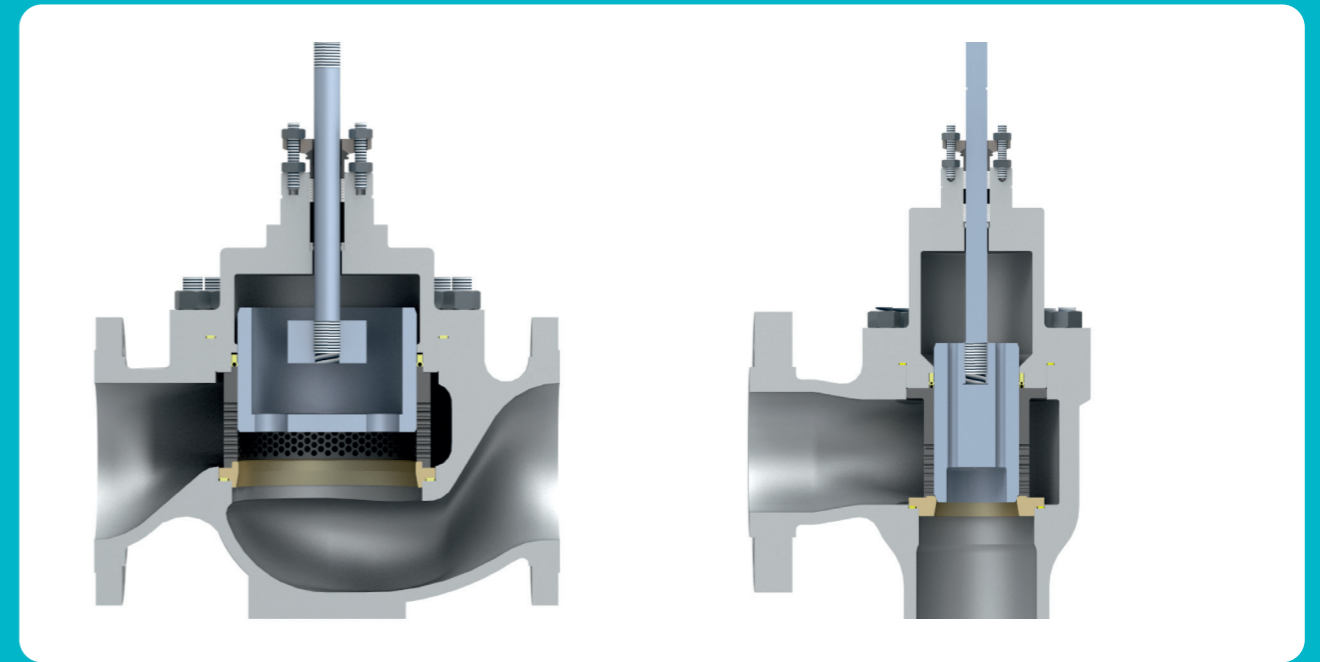
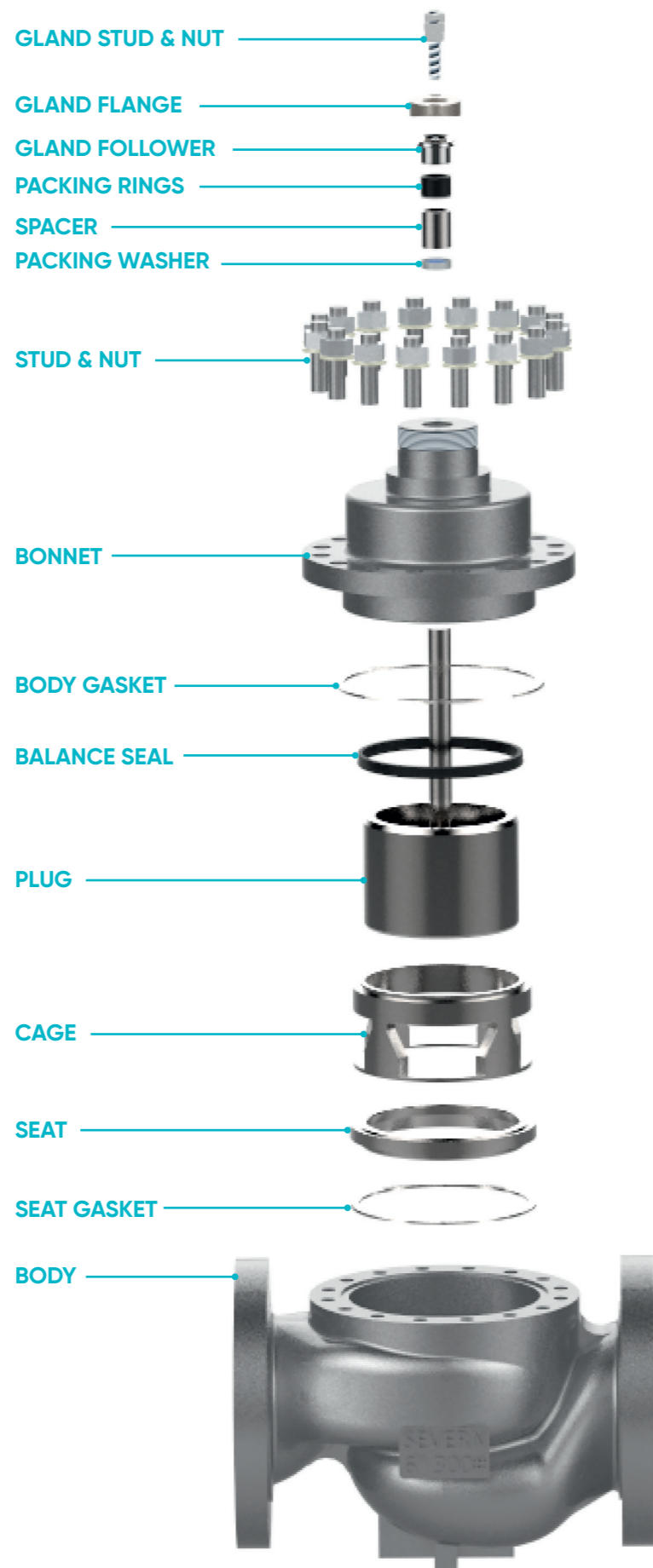

Globe Body

1200 Globe bodies with carefully designed streamlined flow passages offer excellent flow capacities.

Angle Body

1200 Series angle valves are typically offered with reduced seat allowing it to effectively handle increasing fluid velocities in flashing application.

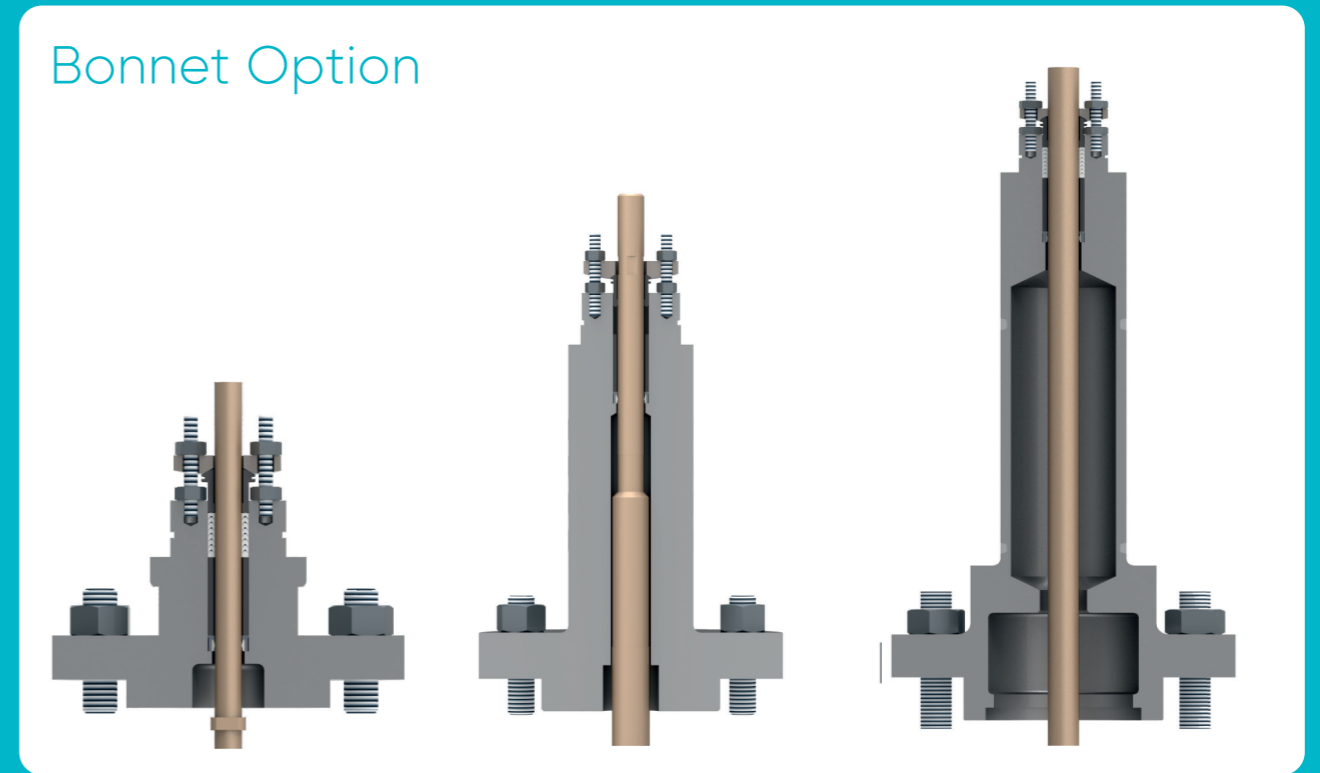

Standard bonnet

The standard bonnet enables the forming of a deep packing box that is suitable for single or double packing with leak off connection. With PTFE packing standard bonnet is suitable to operate in a temperature range -29°C to 232°C.

Extended Bonnet

The extended bonnets are designed to function within the temperature range of -46°C to -29°C and 232°C to 427°C. Its construction protects the packing from high temperature. It accommodates all types of packing boxes that are required to meet stringent emission levels.

Cryogenic Bonnet

The Cryogenic bonnets are designed to typically operate in service conditions with temperature ranging from -46°C to -196°C. The length of the extension is sufficient to maintain the stem packing at temperature that is within normal operating conditions of the packing.

Trim options

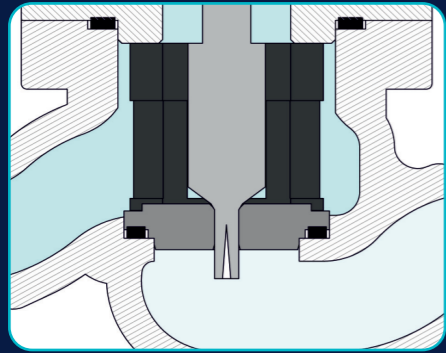

Micro Spline Trim

Where applications call for precise control, both in liquids and gases and when Cv values are very small, the spline trim provides an ideal solution. Consisting of a ground plug in a precision seat bore, the trim components are supplied as a matched set, ensuring the "perfect gravity fit" between the two. Such precision is required in order to achieve impressive turn down of this design.

The tapered groove provided in the valve plug varies the flowing area as the valve travels, being always flowed "over the head" this presents an ever widening flow path to help prevent clogging of the trim. Manufactured in solid hard facing, the spline trim provides maximum erosion resistance and thus ensures prolonged performance in the field.

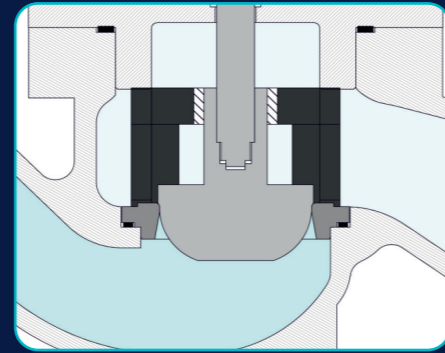

Contoured Trim

Unbalanced contoured plug with extended post guiding enables perfect alignment of the trim components. The trim offers variety of Cv and trim characteristic options along with good rangeability. It is a perfect choice for viscous, dirty fluid and non lubricating process.

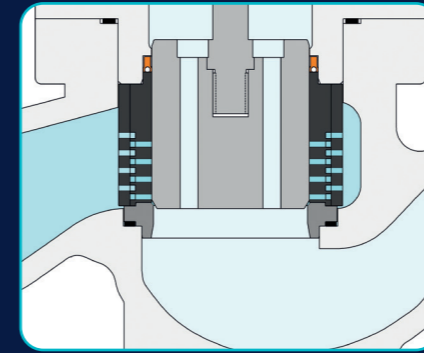

2CC Concentric Cage Trim (Liquid Application)

Single stage let down in high pressure drop liquid applications lead to formation of vapour bubbles, as the static pressure of the fluid falls below the vapour pressure. These bubbles collapse when the static pressure increases above the vapour pressure resulting in cavitation.

The erosive effect of cavitation is controlled by reducing the kinetic energy of the fluid by splitting the flow into many small flow streams. Multiple stage pressure let-down offered by 2CC trims results in low pressure recovery, thereby reducing the possibility of cavitation.

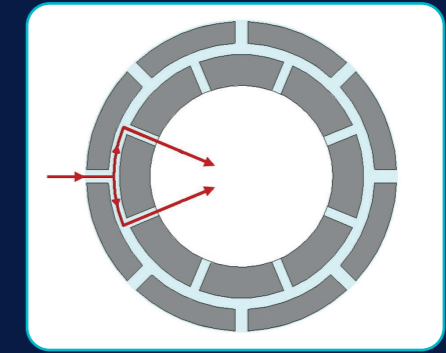

The internal flow resistance offered by co-mingling of the adjacent flow streams acts as additional pressure drop stage, further reducing the pressure recovery.

Any vapour bubbles emanating from the cage assembly are allowed to implode at the middle of the cage (far away from metal surfaces). Localised erosion due to release of enormous kinetic energy by implosion of bubbles is thus avoided. For this purpose, flow-over direction is always recommended for liquid applications. Flow under shall be avoided in order to protect the body gallery (pressure boundary) from the impingement of the fluid jet emanating from outer cage causing damage.

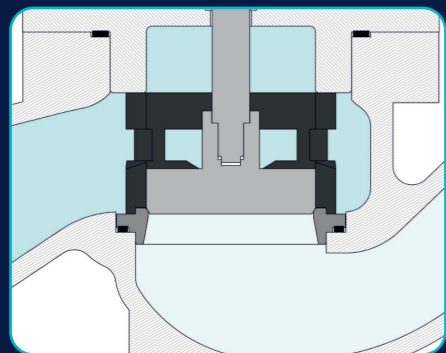

Ported Cage

In this type the trim characteristic is achieved through the profile of the port opening of the cages. Multiple ports enable streamlined flow. Large cage guiding, interchangeability of trim parts and high flow capacity are the defining features of this design. Ported Cage design available in valve size from 2in to 12in, balanced trim option. Both PTFE and graphite balance seals are available for high and low temperature applications.

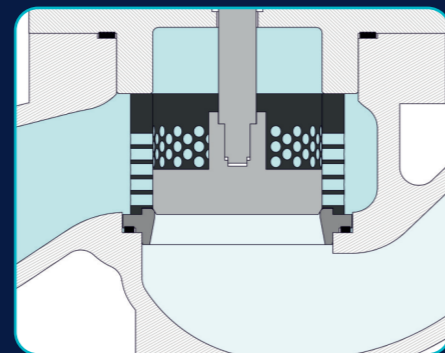

1CC Concentric Cage Trim

Single and multiple heavy section 'drilled hole' cage design offers low pressure recovery that reduce the potential for excessive noise, cavitation, vibration and erosion. The CC trim range has been designed to operate on all fluid combinations, both clean and dirty service.

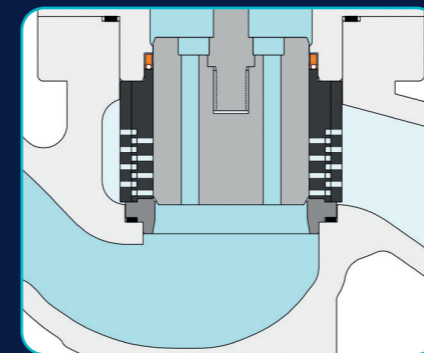

2CC Concentric Cage Trim (Gas Application)

Abrupt single stage pressure reduction in high pressure drop applications may lead to very high noise and vibration. In order to ensure the noise levels do not exceed the specified limits multiple cage designs are used. The noise generation is suppressed at the source by combination of the following.

The fluid flow is split into numerous small flow streams. There by substantially shifting the frequency of the generated noise beyond the audible spectrum. High frequency vibration is easily dampened.

The pressure is dropped in many stages in velocity-controlled manner through an expanding flow passage.

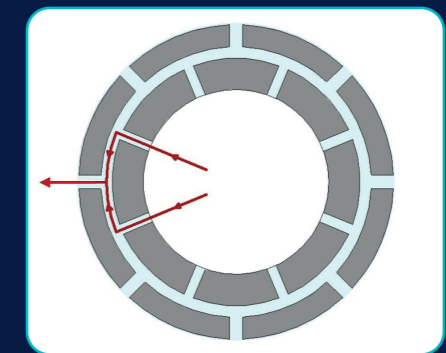

Individual fluid streams emanating from the cage holes are allowed to impinge upon each other in the transfer passageways before taking a right angle turn and entering into the next cage holes. This way noise and vibration are reduced.

Flow under is the preferred flow direction for gas application. Flow over may lead to generation of low frequency secondary noise due to pressure drop at the seat due to increased volume flow of the expanded gas.

Trim options (Continued)

Table 1 – 1200 Series – Trim material combinations

Trim type	Plug	Stem	Seat	Cage	Clamp	Retainer
Contoured/ Micro spline	316	316 / 17-4 PH	316	–	316 + Alloy 6*	–
	316		316 + PTFE	–	316 + Alloy 6*	316
	316 Hard Faced SA		316 Hard Faced SA	–	316 + Alloy 6*	–
	316 Hard Faced FC		316 Hard Faced FC	–	316 + Alloy 6*	–
Cage guided	316 Hard Faced GA	316	316	–	–	
	316 Hard Faced GA 316	316 + PTFE	316	–	316	
	316 Hard Faced FC	316 Hard Faced FC	316	–	–	

SA - Seat Area, FC - Full Contoured, GA - Guide Area. Trim parts are also available in Duplex, Super duplex or Inconel. Soft seat option is not available with micro spline trim. *Hard facing in Clamp is not available with micro spline trim.

Hard Facing

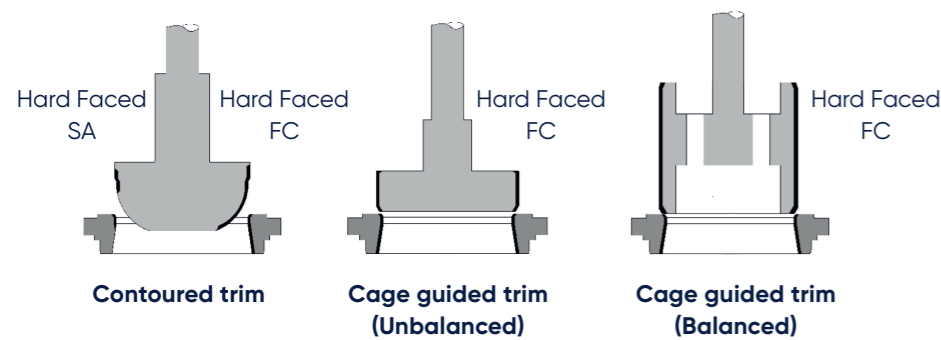

Detail 'A'

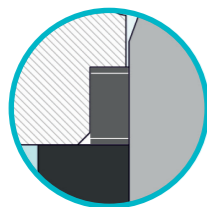

Graphite balance seal

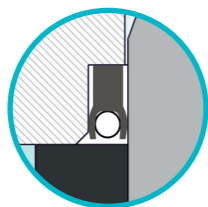

PTFE balance seal

Detail 'B'



Soft seat

1200 Series Valve with Pressure Balanced Trim

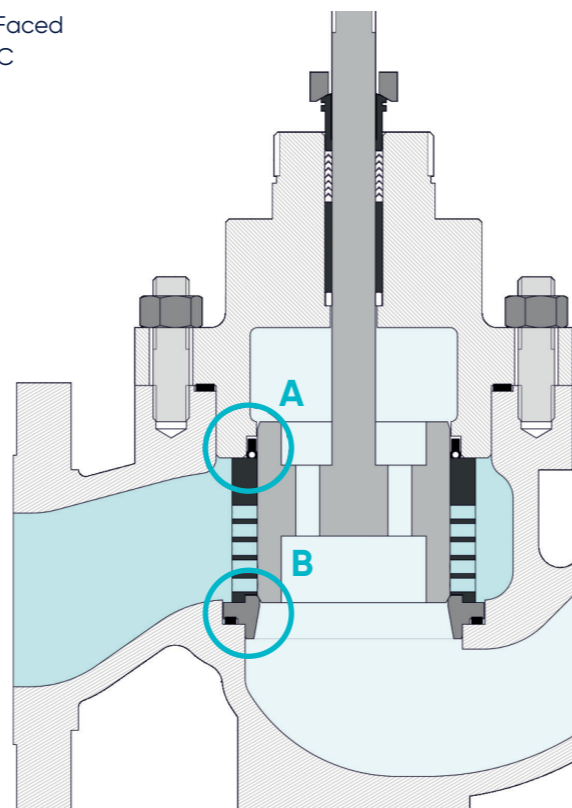

Gland packing options

Variety of packings are available to suit wide ranging requirements of the industry. Most commonly offered packing types include:



PTFE Chevrons

Usually offered as a set of PTFE V-rings, with anti extrusion rings at the ends. May be offered in two sets when used for vacuum service, with inverted V-ring on the top and upright V-ring at the bottom facing the process medium. PTFE Chevrons are preferred for their excellent sealing capability, low friction and cost effectiveness. The operating temperature ranges from -196°C to 232°C.



Graphite packing

These are self lubricating and does not require external lubrication. They are suitable for a wide range of temperatures from -196°C to 450°C. It achieves fugitive emission Class A and Class B as per ISO 15848.



High integrity packing

The packing set consist of two sets of sealing rings and adaptors in cup and cone configuration with varying densities. This arrangement allows selective component compression resulting in effective sealing through out wide ranging temperatures (-196°C to 232°C) and pressures. The packing is also equipped with a spring energized lip seal at the bottom facing the process medium and an anti extrusion ring on the top. It achieves fugitive emission Class B as per ISO 15848.

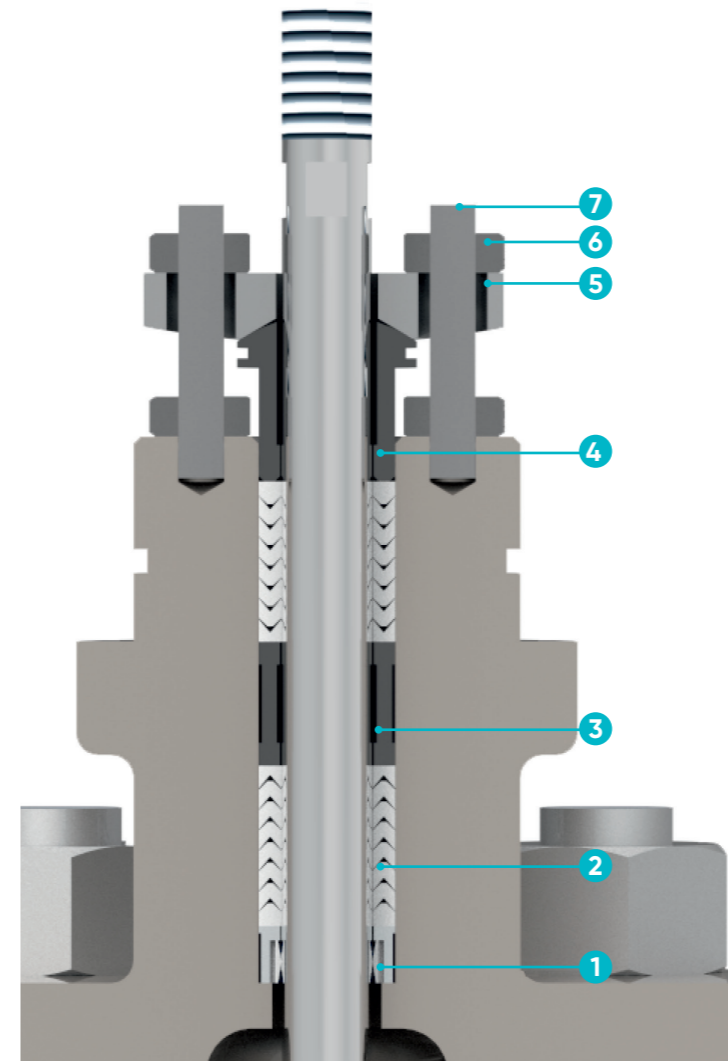

Table 2 – Stuffing box parts and materials

Item No	Component	Material
1	Packing washer*	316SS & Virgin PTFE
2	Packing rings	Virgin PTFE
		Graphite
		Carbon filled PTFE
		Glass filled PEEK PTFE
3	Packing Spacer	316SS
4	Gland follower	316SS Hard faced
5	Gland flange	316SS
6	Gland Nut	316SS
7	Gland Stud	316SS

*Note (1): Packing box ring shall be used for higher temperatures.
Note (2): Stuffing Box material is available based on trim material.

Flow Coefficients Cv

Table 3 – Microspline (Available in 1 and 1 1/2 inch size only)

Flow Over

Seat Bore (Travel)							
0.250(0.75)						0.625 (0.75)	
0.01	0.05	0.10	0.15	0.25	0.50	0.95	1.45

Table 4 – Contoured

Valve Size (Inch)	Seat Bore (Inch)	Travel (Inch)	Flow Under	
			Linear	EP
1	0.25	0.75	1.60	1.40
	0.375	0.75	3.50	3.50
	0.5	0.75	6.00	6.00
	0.625	0.75	9.50	9.00
	0.75	0.75	11.50	10.50
	0.875	0.75	15	14
	1	0.75	18	15
1.5	0.25	0.75	1.60	1.60
	0.375	0.75	3.50	3.50
	0.5	0.75	6.00	6.00
	0.625	0.75	9.50	9.00
	0.75	0.75	13	12
	0.875	0.75	16	16
	1	0.75	20	19
	1.125	0.75	24	23
	1.25	0.75	27	26
2	0.25	0.75	1.60	1.60
	0.375	0.75	3.70	3.70
	0.5	0.75	6.20	6.20
	0.625	0.75	9.50	9.00
	0.75	0.75	13	13
	0.875	0.75	17	17
	1	0.75	22	21
	1.5	0.75	46	43
	2	0.75	59	51
3	1.5	0.75	49	46
	2	0.75	80	54
	2.625	1.5	105	95
	3	1.5	127	103
4	2.625	1.5	135	127
	3	1.5	159	135

 Soft seat option available

Table 5 – Cage guided - 1CC Cage

Valve Size (Inch)	Seat Bore* (Inch)	Travel (Inch)	Flow Over			Flow Under			
			Linear	EP	Bi-Linear	Linear	EP	Bi-Linear	
1	0.625	0.75	2	2	-	2	2	-	
			4	4	-	4	4	-	
			6	6	7	7	7	8	
	1	0.75	9	8	-	9	8	-	
			12	10	-	13	10	-	
1.5	0.625	0.75	16	12	14	16	12	15	
			2	2	-	2	2	-	
			4	4	-	4	4	-	
	1	0.75	6	6	8	7	7	8	
			9	8	-	10	8	-	
			14	10	-	14	10	-	
	1.5	1.125	18	12	15	20	13	16	
			24	22	-	25	23	-	
			32	27	26	32	28	27	
	2	0.625	0.75	24	22	-	25	23	-
				2	2	-	2	2	-
				4	4	-	4	4	-
		1	0.75	6	6	8	7	7	8
				9	8	-	10	8	-
				13	10	-	14	11	-
2.25		1.125	19	12	16	21	13	18	
			36	37	-	38	37	-	
			44	41	-	47	43	-	
3		1.125	59	50	50	62	54	53	
			77	61	60	84	63	62	
4		1.5	134	111	120	133	117	122	
	162		125	142	178	136	157		
6	2.25	224	198	201	217	196	203		
		292	240	253	314	270	286		
8	2.25	432	367	376	418	378	381		
		548	440	456	586	476	495		
10	3.5	781	691	715	712	653	668		
		802	704	727	849	745	777		
12	3.5	849	779	849	982	861	914		
		951	779	849	982	861	914		
12	4	1294	1241	1072	1356	1297	1166		
		1294	1241	1072	1356	1297	1166		

EP - Equal Percentage

1CC - For Cavitating / Flashing service use flow over. Flow under is suitable for aerodynamic noise reduction.

Rated flow capacity for soft seated valves is 98% as that of metal seated valves.

*For soft seated design the seat bore (S) size shall be 'S - 0.069 inches'.

Flow Coefficients Cv (Continued)

Table 6 – Cage guided – Ported cage (only Balanced)

Valve Size (Inch)	Seat Bore* (Inch)	Travel (Inch)	Flow Over	
			Linear	EP
2	2.25	1.125	73	52
3	2.25	1.125	92	58
	3.25	1.5	148	121
4	3.25	1.5	183	139
	4.375	2.25	242	199
6	4.375	2.25	312	255
	6.75	2.25	440	383
8	6.75	2.25	618	483
	8	3.5	835	749
10	8	3.5	941	834
12	8	3.5	1058	940
	11	4	1476	1327

Table 7 – Cage guided – 2 CC Cage

Valve Size (Inch)	Seat Bore* (Inch)	Travel (Inch)	Linear	
			Flow Over	Flow Under
2	2.25	1.125	30	25
3	2.25	1.125	37	30
	3.25	1.5	72	61
4	3.25	1.5	75	64
	4.375	2.25	136	117
6	4.375	2.25	160	140
	6.75	2.25	239	199
8	6.75	2.25	260	218
	8	3.5	497	421
10	8	3.5	501	436
12	8	3.5	558	473
	11	4	812	721

Table 8 – Cage guided - 2 CC Cage

Valve Size (Inch)	Seat Bore* (Inch)	Travel (Inch)	Bi-Linear	
			Flow Over	Flow Under
2	2.25	1.125	28	23
3	2.25	1.125	32	25
	3.25	1.5	62	52
4	3.25	1.5	69	54
	4.375	2.25	115	108
6	4.375	2.25	130	124
	6.75	2.25	201	168
8	6.75	2.25	215	179
	8	3.5	418	352
10	8	3.5	418	362
12	8	3.5	450	370
	11	4	650	605

Rated flow capacity for soft seated valves is 98% as that of metal seated valves.

*For soft seated design the seat bore size shall be 'S - 0.069 inches'.

Dimensions and weights

Table 9 – Dimensions and weights

Valve size	Seat Bore	Stem dia	DIM A			DIM B			DIM C		Approx. weight (kg)					
			150#	300#	600#	150#	300#	600#	Unbal	Bal	Unbalanced			Balanced		
											150#	300#	600#	150#	300#	600#
1	Various	0.5	184	197	210	54	62	62	144	-	12	13	14	-	-	-
1.5	Various	0.5	222	235	251	64	78	78	144	-	20	23	24	-	-	-
2	Various	0.5	254	267	286	76	83	83	144	164	28	31	37	29	31	38
3	above 2.25	0.75	353	368	394	121	133	143	175	184	61	74	95	63	76	97
6	6.75	1, 1.25	451	473	508	149	168	187	-	248	-	-	-	144	174	241
8	8	1.25	543	568	610	197	203	222	-	314	-	-	-	215	268	386
12	8	1.25	737	775	819	254	270	279	-	305	-	-	-	397	499	727

Note (1): Consider the unit as 'mm' when the same is not indicated.

Note (2): Actual weight will be ± 5% of given weight in above table.

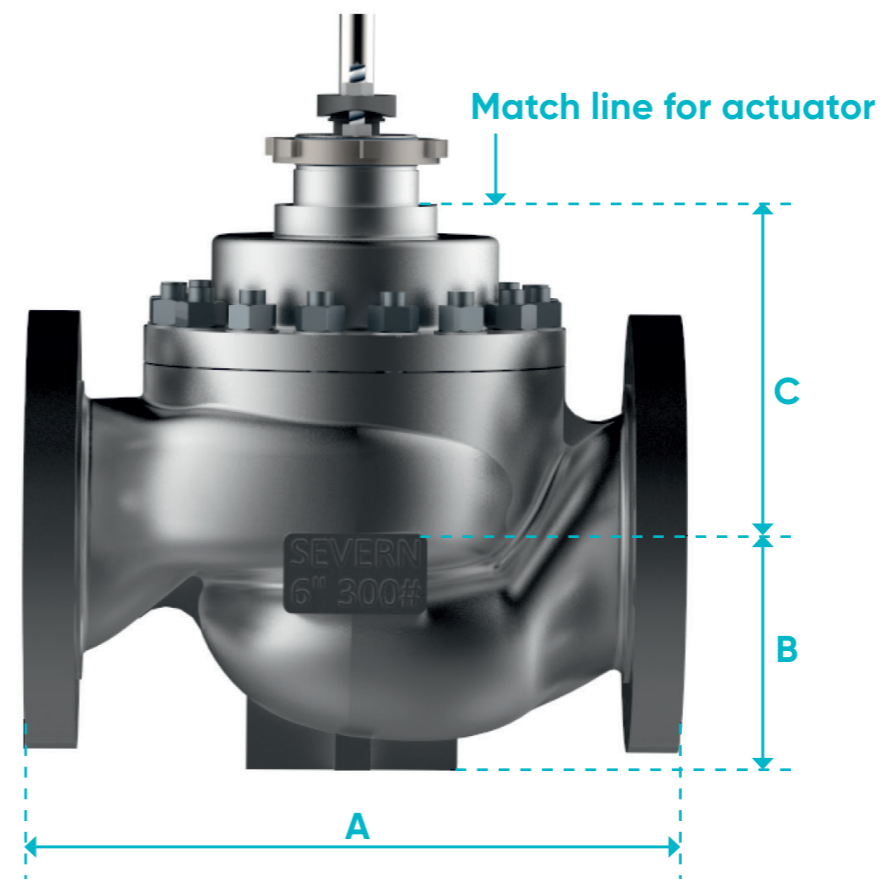

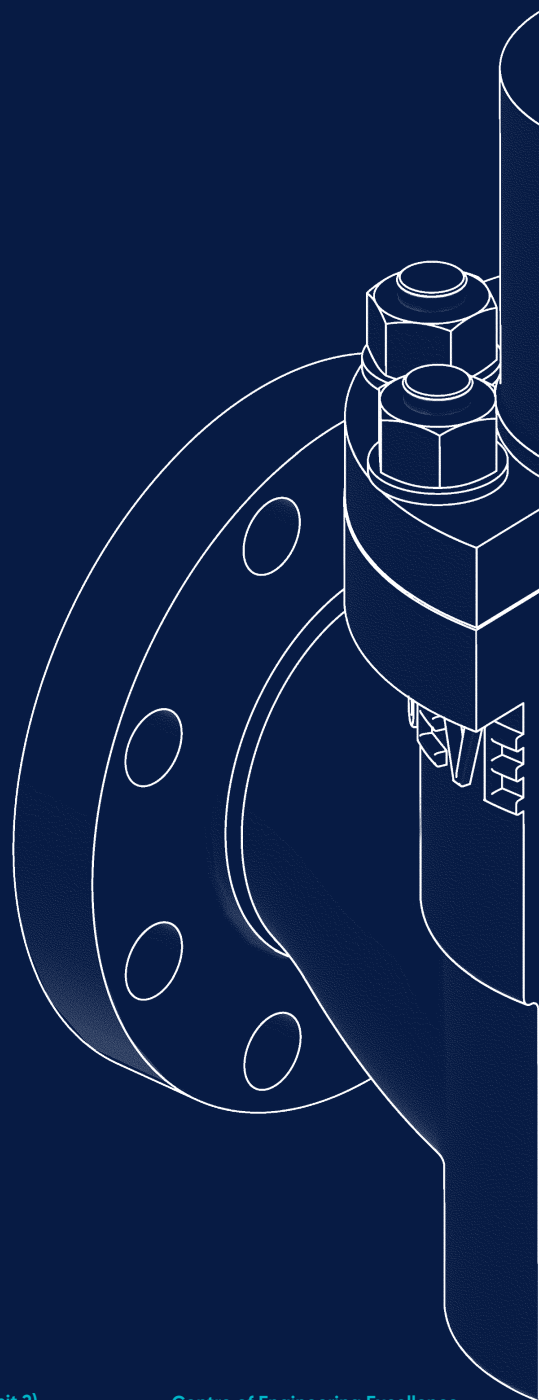

Engineering
Excellence

Gloucester UK (HQ)

Olympus Park,
Quedgeley,
Gloucester, GL2 4NF.

T: +44 (0)845 223 2040
E: sales@severnvalve.com

Severn India (Unit 1)

F96 & F97, SIPCOT Industrial Park,
Irrungattukottai, Chennai,
Tamilnadu, India - 602 117.

T: +91 44 4710 4200
E: sales@severnvalve.com

Severn India (Unit 2)

A-50, SIPCOT Industrial Growth
Centre, Oragadam, Chennai -
Tamilnadu, India - 602105

T: + 044 67123200
E: sales@severnvalve.com

Centre of Engineering Excellence

Crossley Mills, Dean Clough,
Halifax, HX3 5AX

T: +44 (0)845 6070 710
E: sales@severnvalve.com

www.severnvalve.com

Our policy is one of continuous improvement and we reserve the right to modify these specification details without notice.

V1.3